

Parts List for Size 5.5 CFCB Clutch-Brakes

Serial and model numbers from nameplate are required when ordering replacement parts.

2-13-5531-01 standard
2-13-5531-16 spring release

See reverse side for Tor-ac model.

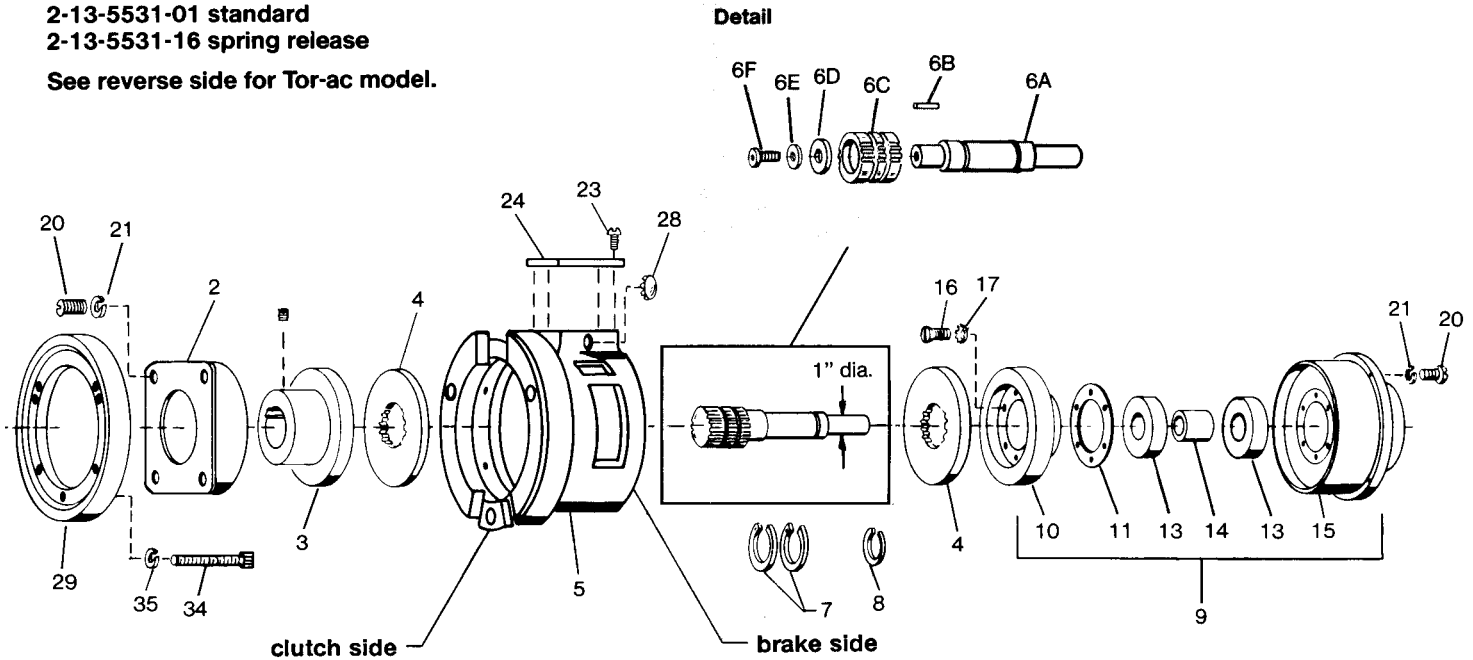

TABLE A

Item No.	Description	Part Number	Qty.
2	Magnet body and coil assembly - clutch 90-100 volts, DC 24-28 volts, DC 12 volts, DC 6 volts, DC	5-04-0055-01-01J	1
		5-04-0055-01-01E	1
		5-04-0055-01-01C	1
		5-04-0055-01-01B	1
3	Drivehub (1" diameter) Drivehub (1½" diameter) Drivehub (1¾" diameter)	5-30-0510-02-10Q 5-30-0510-02-10R 5-30-0510-02-10U	1 1 1
4	Armature	8-405-023-07	2
5	Housing	8-443-015-01	1
6A	Shaft - brake (1" diameter)	8-464-055-00	1
6B	Key	9-50-1012-00	1
6C	Hub	8-411-055-02	1
6D	Belleville washer	9-71-2121-00	1
6E	Belleville washer	9-71-2081-01	1
6F	Screw	9-16-3010-00	1
7	Retaining ring	9-03-0014-00	2
8	Retaining ring	9-03-0005-00	1
9	Brake assembly (includes items 10 through 17) 90-100 volts, DC 24-28 volts, DC 12 volts, DC 6 volts, DC	5-40-5055-00-01J	1
		5-40-5055-00-01E	1
		5-40-5055-00-01C	1
		5-40-5055-00-01B	1
10	Friction face assembly	5-30-0506-00	1
11	Spacer	8-455-040-01	1
13	Ball bearing	9-01-0016-00	2
14	Spacer	8-455-039-00	1
15	Magnet body and coil assembly - brake 90-100 volts, DC 24-28 volts, DC 12 volts, DC 6 volts, DC	5-04-0055-03-01J	1
		5-04-0055-03-01E	1
		5-04-0055-03-01C	1
		5-04-0055-03-01B	1

TABLE A (continued)

Item No.	Description	Part Number	Qty.
16	Flat head screw	9-11-4610-00	8
17	Lock washer	9-45-0726-00	8
20	Round head screw	9-10-3012-00	8
21	Lock washer	9-45-0330-00	8
23	Self tapping screw	9-25-7309-00	4
24	Nameplate	-	1
28	Snap-in blank	9-61-1150-00	1
29	Adapter - clutch side	8-445-504-01	1
34	Cap screw	9-17-1444-00	3
35	Lock washer	9-45-1334-00	3
not shown	Installation and Maintenance Sheet (CFCB)	8-078-800-03	1

TABLE B

For spring release use:		
Release spring	8-404-829-01	2 required
Screw	9-16-2705-00	6 required
Lock washer	9-45-0527-00	6 required

TABLE C

For case hardened armature use in place of item 4:		
Armature	8-405-023-14	2 required

Parts List for Size 5.5 CFCB Tor-ac® Clutch-Brakes

Serial and model numbers from nameplate are required when ordering replacement parts.

2-13-5571-00 Tor-ac standard
2-13-5571-01 Tor-ac spring release

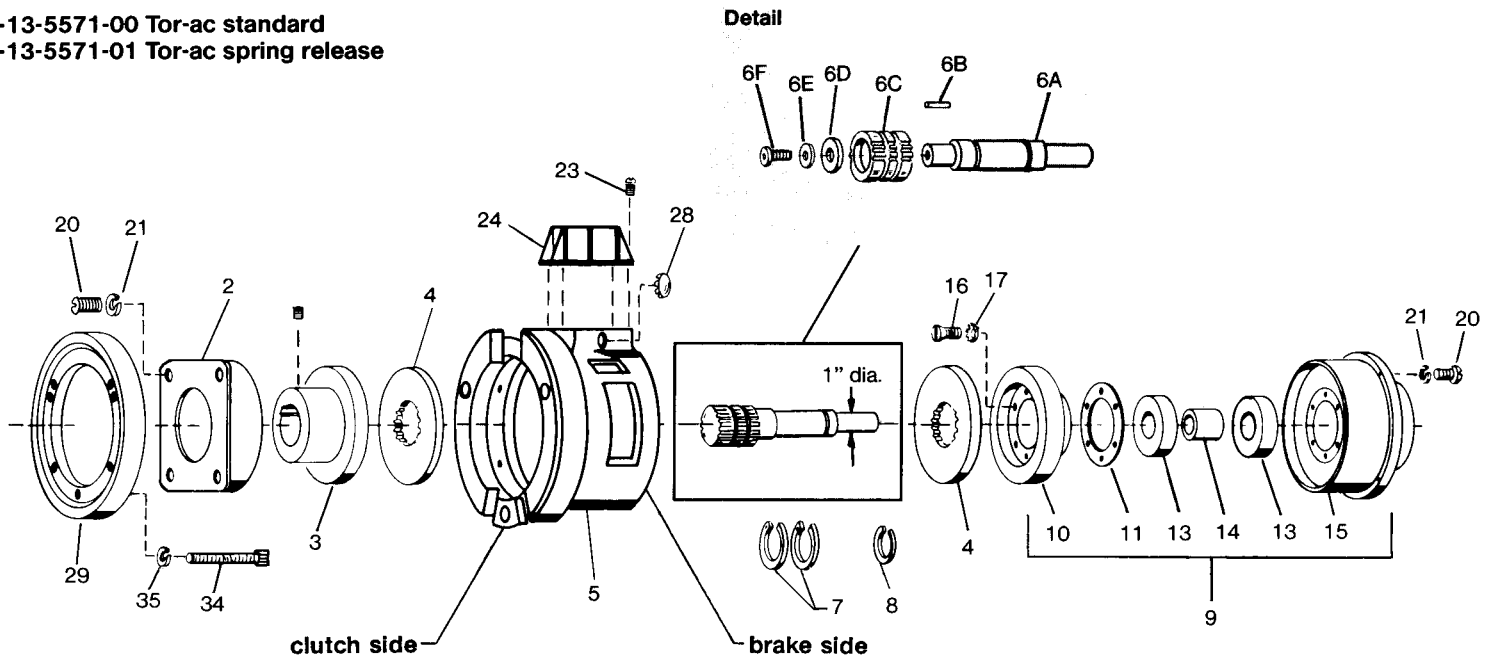

TABLE D

Item No.	Description	Part Number	Qty.
2	Magnet body and coil assembly - clutch 90-100 volts, DC	5-04-0055-01-01J	1
3	Drivehub (1" diameter)	5-30-0510-02-10Q	1
	Drivehub (1 1/8" diameter)	5-30-0510-02-10R	1
	Drivehub (1 3/8" diameter)	5-30-0510-02-10U	1
4	Armature	8-405-023-07	2
5	Housing	8-443-015-01	1
6A	Shaft - brake (1" diameter)	8-464-055-00	1
6B	Key	9-50-1012-00	1
6C	Hub	8-411-055-02	1
6D	Belleville washer	9-71-2121-00	1
6E	Belleville washer	9-71-2081-01	1
6F	Screw	9-16-3010-00	1
7	Retaining ring	9-03-0014-00	2
8	Retaining ring	9-03-0005-00	1
9	Brake assembly (includes items 10 through 17) 90-100 volts, DC	5-40-5055-00-01J	1
10	Friction face assembly	5-30-0506-00	1
11	Spacer	8-455-040-01	1
13	Ball bearing	9-01-0016-00	2
14	Spacer	8-455-039-00	1
15	Magnet body and coil assembly - brake 90-100 volts, DC	5-04-0055-03-01J	1
16	Flat head screw	9-11-4610-00	8
17	Lock washer	9-45-0726-00	8

TABLE D (continued)

Item No.	Description	Part Number	Qty.
20	Round head screw	9-10-3012-00	8
21	Lock washer	9-45-0330-00	8
23	Self tapping screw	9-25-7309-00	4
24	Tor-ac power supply (115 VAC input)	4-1-20190-00	1
28	Snap-in blank	9-61-1150-00	1
29	Adapter - clutch side	8-445-504-01	1
34	Cap screw	9-17-1444-00	3
35	Lock washer	9-45-1334-00	3
not shown	Installation and Maintenance Sheet (Tor-ac CFCB)	8-078-857-01	1
not shown	Tor-ac Instructions Tag	8-078-861-00	1

TABLE E

For spring release use:		
Release spring	8-404-829-01	2 required
Screw	9-16-2705-00	6 required
Lock washer	9-45-0527-00	6 required

TABLE F

For case hardened armature use in place of item 4:		
Armature	8-405-023-14	2 required