

## Parts List for 65,300-05 Series Brakes (rev. E)

### Information required when ordering replacement parts:

- When ordering brake parts, give part number of parts or kits needed, brake model number, and brake serial number. The brake model and serial number may identify special brakes not covered by this parts list.
- When ordering hubs, specify shaft diameter (hub bore) and keyway.

For installation and service instructions, see P/N 8-078-925-13.  
Detailed service instruction sheet is included with each kit.

### Note:

- This brake series is listed by UL (Underwriters Laboratories) for use in certain locations classified as hazardous. Installation and servicing must be in compliance with all

existing local safety codes. All wiring and electrical connections must comply with the National Electric Code (NEC) and local electrical codes in effect at the time. For additional information see the Underwriters Laboratories (UL) website <http://www.ul.com/hazloc/codes/html>.

- HazLoc inspection authorities are responsible for verifying and authorizing the use of suitably designed, manufactured and installed HazLoc equipment. When questions arise always consult the local **Authority Having Jurisdiction (AHJ)** for directions and approvals.

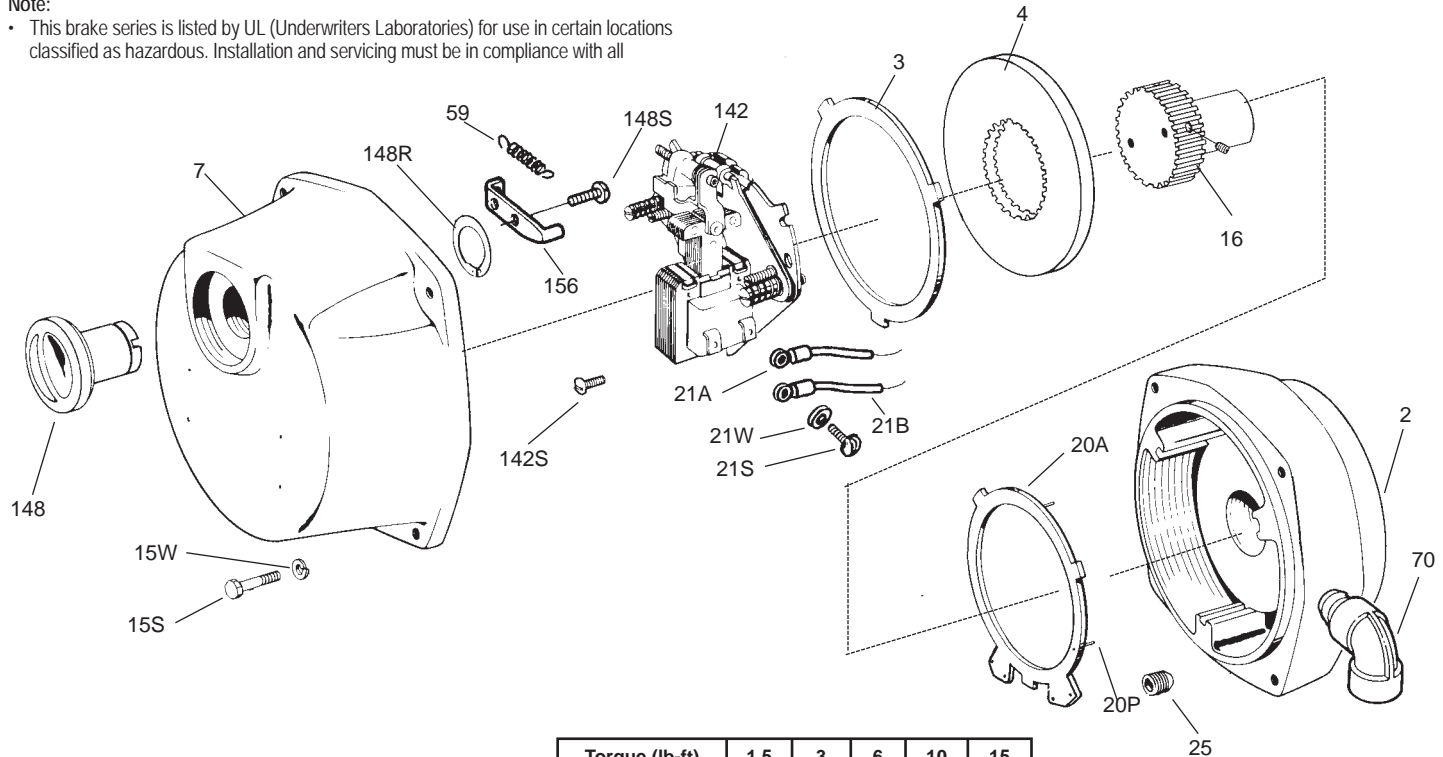

**TABLE 1**  
Components of 65,300 Series Brakes

Item No. or Kit No.	Description	Part Number ↓	Torque (lb-ft)				
			1.5	3	6	10	15
Brake Model Number →			1-065-311-05	1-065-321-05	1-065-331-05	1-065-351-05	1-065-361-05
2**	Endplate assembly**	5-50-5120-00-30*	1	1	1	1	1
3	Stationary disc kit (universal mount)	5-66-8354-00	1	1	1		
	Stationary disc kit (universal mount)	5-66-8355-00				1	1
4	Friction disc kit - splined	5-66-8458-00	1	1	1	2	2
7	Housing and release assembly	5-07-5015-03	1	1	1	1	1
15S	Cap screw hex head 3/8 - 16 x 1.25 grade 5	9-17-3220-00	4	4	4	4	4
15W	Lock washer 3/8"	9-45-1332-00	4	4	4	4	4
16	Splined hub and set screw assembly	5-16-5140-00	1	1	1	1	1
20A	Insulator disc	8-003-505-01	1	1	1	1	1
20P	Spirol pin 3/32 dia. x 5/8 flared head, stainless steel	9-32-2003-00	3	3	3	3	3
21A	Thermostat and lead wire (red leads)	5-57-5001-00	1	1	1	1	1
21B	Thermostat and lead wire (yellow leads)	5-57-5002-00	1	1	1	1	1
21S	Machine screw, round head #5 - 40 x 1/4	9-10-2504-00	4	4	4	4	4
21W	Lock washer, spring #5 med	9-45-0325-00	4	4	4	4	4
25	Set screw 3/4 - 16 x 3/4	9-23-0023-00	4	4	4	4	4
59	Release spring	9-71-0005-00	1	1	1	1	1
70	Elbow	9-33-3004-00	1	1	1	1	1
142	Support plate assembly (see Table 2)						
142S	Thread rolling screw	9-25-9013-00	3	3	3	3	3
156	Release arm	8-156-510-01	1	1	1	1	1
148	Release knob	8-148-504-05	1	1	1	1	1
148R	Retaining ring truarc #5108-100-ZD	9-03-0001-00	1	1	1	1	1
148S	Machine screw	9-10-2706-00	1	1	1	1	1

\*Last digit depends upon location of elbow; specify brake model number when ordering

\*\* Includes 20A, 20P, 21A, 21B, 21S, 21W, 25, 70, 142S

**TABLE 2**  
Components of Support Plate and Coil Assembly

Item	Description	Part Number↓	Torque (lb-ft)			
			1.5 & 3	6 & 10	15	
			5-42-5577-00	5-42-5578-00	5-42-5579-00	
6	Bearing	8-006-501-00	1	1	1	
8	Solenoid lever	8-008-504-01	1	1	1	
8R	Retaining ring	9-03-0057-00	1	1	1	
8W	Spacer	9-45-0168-00	2	2	2	
11N	Torque adjustment nut	9-40-3928-00	2	2	2	
10	Wear adjustment screw	8-351-021-00	2	2	2	
11	Pressure spring	9-70-1215-00	2			
	Pressure spring	9-70-1523-00		2		
	Pressure spring	9-70-1524-00			2	
11W	Spring washer	9-46-0010-00		4	4	
17	Lever arm and stop nut assembly	5-17-5011-00	1	1	1	
26	Bearing pin	9-29-4826-00	1	1	1	
29A	Plunger stop	8-094-503-00	1	1	1	
126	Support plate and spring stud assembly	5-26-5021-00	1	1	1	
131	Pivot pin	9-29-4836-00	1	1	1	
142S	Mounting screws	9-25-9013-00	3	3	3	
Z	No. 4 solenoid kit	5-96-5042-00	1	1	1	
12	No. 4 coil kit 60 Hz	115/230 Vac	5-96-6407-05	1		
		230/460 Vac	5-96-6409-05	1		
		115 Vac	5-96-6401-05	1		
		230 Vac	5-96-6402-05	1		
		460 Vac	5-96-6404-05	1		
	No. K4 coil kit 60 Hz	115/230 Vac	5-96-6457-05		1	
		230/460 Vac	5-96-6459-05		1	
		115 Vac	5-96-6451-05		1	
		230 Vac	5-96-6452-05		1	
		460 Vac	5-96-6454-05		1	
	No. K4+ coil kit 60 Hz	115/230 Vac	5-96-6407-25			1
		230/460 Vac	5-96-6409-25			1
		115 Vac	5-96-6401-25			1
		230 Vac	5-96-6402-25			1
		460 Vac	5-96-6404-25			1
	575 Vac	5-96-6405-25			1	

**Support Plate Assembly**

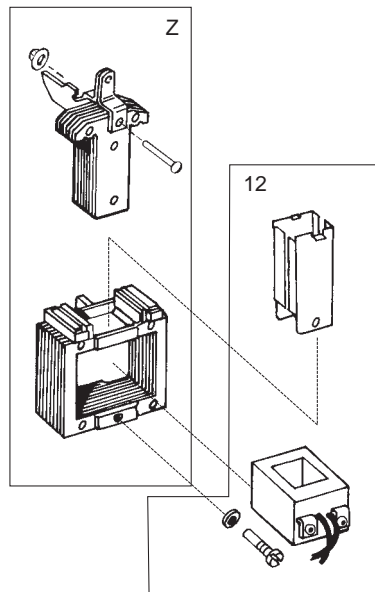
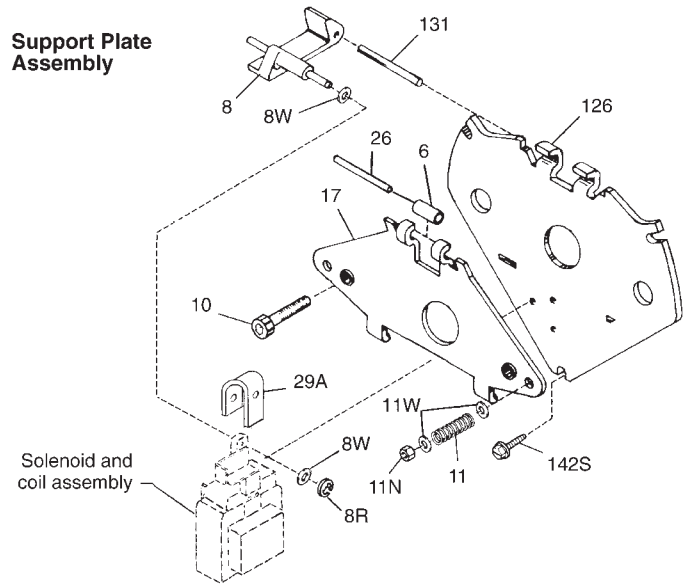

**TABLE 3**  
Contents of Kits and Assemblies

Item Designation	Kit Description
3	Stationary disc kit (5-66-8354-00) 1 - Stationary disc Stationary disc kit (5-66-8355-00) 2 - Stationary discs with springs
4	Friction disc kit (5-66-8458-00) 1 - Friction disc (spline)
Z	No. 4 solenoid kit (5-96-5042-01) 1 - Plunger 1 - Solenoid link 1 - Frame 1 - Solenoid link cap screw 1 - Solenoid link nut 3 - Solenoid mounting screws
12	No. 4 AC coil kit (5-96-64XX-X5) Coil Plunger guides Wire nut



Rexnord Industries, LLC  
Stearns Division  
5150 S. International Dr.  
Cudahy, WI 53110  
(414) 272-1100 Fax: (414) 277-4364 [www.stearns.rexnord.com](http://www.stearns.rexnord.com)