

Parts List for 1-056-700 Series (Rev. C) Double C-Face Coupler

For Rev. C Installation and Service Instructions refer to sheet part number 8-078-905-69. Instructions and parts list also available at www.stearns.rexnord.com.

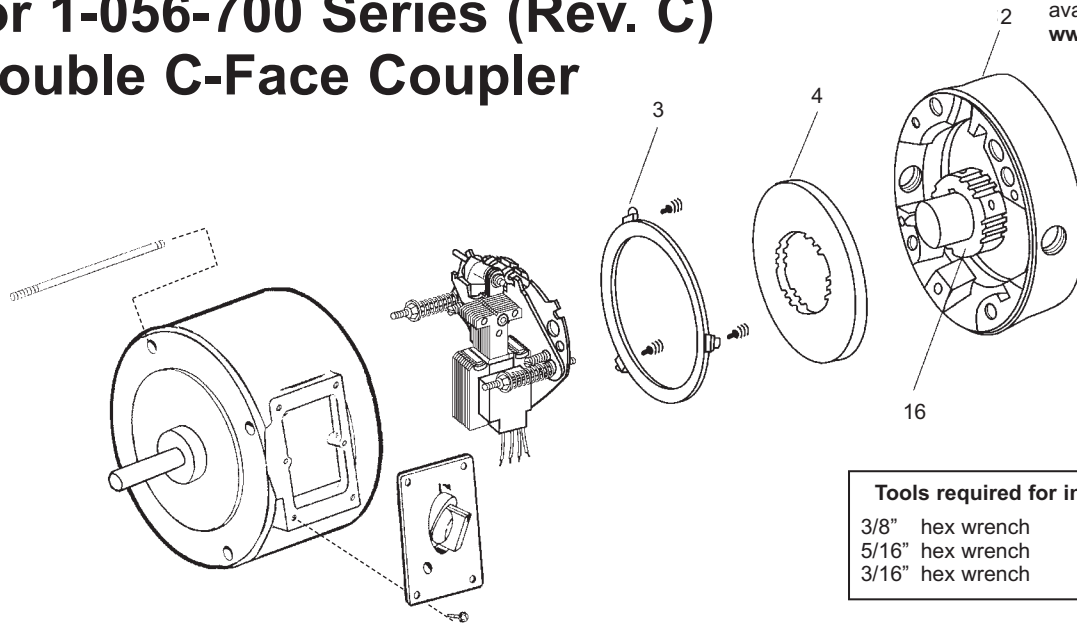

Tools required for installation and servicing:	
3/8" hex wrench	5/16" nut driver
5/16" hex wrench	1/4" screwdriver
3/16" hex wrench	8" adjustable wrench

Typical Nameplate

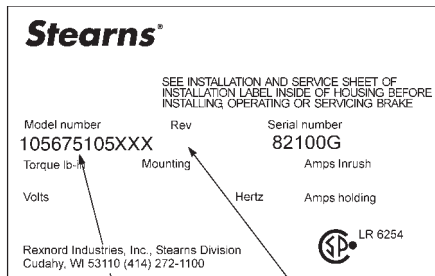

MODEL NUMBER
Refer to actual nameplate on brake for additional information

REVISION CONTROL

Important

Please read these instructions carefully before installing, operating, or servicing your Stearns Brake. Failure to comply with these instructions could cause injury to personnel and/or damage to property if the brake is installed or operated incorrectly. For definition of limited warranty/liability, contact Rexnord Industries, LLC, Stearns Division, 5150 S. International Dr., Cudahy, WI 53110, (414) 272-1100.

Caution

1. Installation and servicing must be made in compliance with all local safety codes including Occupational Safety and Health Act (OSHA). All wiring and electrical connections must comply with the National Electric Code (NEC) and local electric codes in effect.

2. Do not install the brake in atmospheres containing explosive gases or dusts.
3. To prevent an electrical hazard, disconnect power source before working on the brake. If power disconnect point is out of sight, lock disconnect in the *off* position and tag to prevent accidental application of power.
4. Make certain power source conforms to the requirements specified on the brake nameplate.
5. Be careful when touching the exterior of an operating brake. Allow sufficient time for brake to cool before disassembly. Surfaces may be hot enough to be painful or cause injury.
6. Do not operate brake with housing removed. All moving parts should be guarded.
7. Installation and servicing should be performed only by qualified personnel familiar with the construction and operation of the brake.
8. For proper performance and operation, only genuine Stearns parts should be used for repairs and replacements.
9. After usage, the brake interior will contain burnt and degraded friction material dust. This dust must be removed before servicing or adjusting the brake.

DO NOT BLOW OFF DUST using an air hose. It is important to avoid dispersing dust into the air or inhaling it, as this may be dangerous to your health.

- a) Wear a filtered mask or a respirator while removing dust from the inside of a brake.
- b) Use a vacuum cleaner or a soft brush to remove dust from the brake. When brushing, avoid causing the dust to become airborne. Collect the dust in a container, such as a bag, which can be sealed off.

Caution! While the brake is equipped with a manual release to allow manual shaft rotation, the motor should not be run with the manual release engaged, to avoid overheating the friction disc(s).

Information required when ordering replacement parts:

- Give part number of parts or kits needed, brake model number, and brake serial number. The brake model and serial number may identify special brakes not covered by this parts list.
- When ordering hubs, specify shaft diameter (hub bore) and keyway.
- Enclosure is specified as follows:

NEMA 1 (formerly referred to as standard)
 NEMA 4 (formerly referred to as DTWP dust-tight waterproof)
 NEMA 4X (formerly referred to as BISSC washdown)

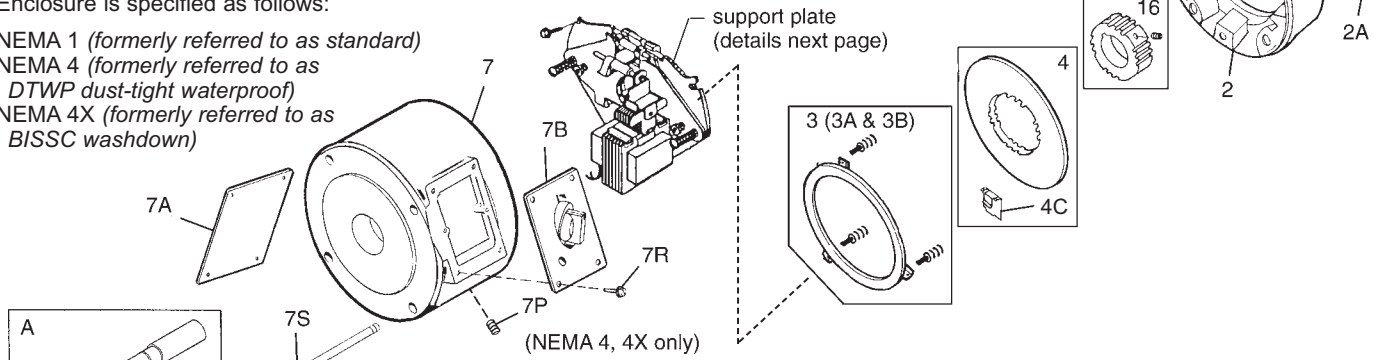

Torque (lb-ft)	1.5 & 3			6			10			15			20 & 25																																																																													
	Current			Current			Current			Current			Current																																																																													
	AC	DC	4X	AC	DC	4X	AC	DC	4X	AC	DC	4X	AC	DC	4X																																																																											
NEMA Enclosure	2	4	4X	2	4	4X	2	4	4X	2	4	4X	2	4	4X																																																																											
Brake Model Number →	1-056-701-00 & 711-00			1-056-702-00 & 712-00			1-056-704-00 & 714-00			1-056-705-00 & 715-00			1-056-706-00 & 716-00			1-056-708-00 & 718-00			1-056-721-00			1-056-722-00			1-056-724-00			1-056-725-00			1-056-726-00			1-056-728-00			1-056-731-00			1-056-732-00			1-056-734-00			1-056-735-00			1-056-736-00			1-056-738-00			1-056-741-00			1-056-742-00			1-056-744-00			1-056-745-00			1-056-746-00			1-056-748-00			1-056-751-00 & 761-00			1-056-752-00 & 762-00			1-056-754-00 & 764-00			1-056-755-00 & 765-00			1-056-756-00 & 766-00			1-056-758-00 & 768-00		

TABLE 1
 Components of Standard AC or DC Brake

Item	Description	Part Number ↓	1.5 & 3			6			10			15			20 & 25		
			AC	DC	4X	AC	DC	4X	AC	DC	4X	AC	DC	4X	AC	DC	4X
A	Coupler brake shaft kit (5/8 diameter) Coupler brake shaft kit (7/8 diameter) Coupler brake shaft kit - 3 disc (7/8 dia.)	5-66-8865-00 5-66-8867-00 5-66-8869-00	1	1	1	1	1	1	1	1	1	1	1	1	1	1	1
7	Housing - standard (NEMA 2) Housing - DTWP (NEMA 4) Housing - BISSC (NEMA 4X)	8-007-527-09 8-007-527-11 8-007-527-12	1		1		1		1		1		1		1		1
7S	Mounting stud kit (NEMA 2 & 4) Mounting stud kit (NEMA 4X)	5-96-0527-00 5-96-0528-00	1	1	1	1	1	1	1	1	1	1	1	1	1	1	1
7A	Access cover (NEMA 2) Access cover (NEMA 4) Access cover (NEMA 4X)	8-104-505-00 8-104-506-00 8-104-506-01	1		1		1		1		1		1		1		1
7B	Manual release assembly (NEMA 2) Manual release assembly (NEMA 4) Manual release assembly (NEMA 4X)	5-07-5033-00 5-07-5037-00 5-07-5038-00	1		1		1		1		1		1		1		1
7R	Machine screw	9-25-7321-00	4	12	12	4	12	12	4	12	12	4	12	12	4	12	12
not shown	Release Knob Kit	5-63-5503-00	1	1		1	1		1	1		1	1		1	1	
not shown	Gasket - access cover (NEMA 4 & 4X)	8-073-504-00	2	2		2	2		2	2		2	2		2	2	
not shown	Gasket - housing to endplate (NEMA 4 & 4X)	8-069-506-00	1	1		1	1		1	1		1	1		1	1	
not shown	Gasket - brake ends (NEMA 4 & 4X)	8-122-501-00	2	2		2	2		2	2		2	2		2	2	
7P	Pipe plug (drain) Pipe plug (stainless drain)	9-33-0325-00 9-33-0325-01	1		1		1		1		1		1		1		1
3	Stationary disc kit (1 disc universal 3 disc horizontal)	5-66-8354-00	1	1	1	1	1	1	1	1	1	1	1	1	1	1	1
3A	Stationary disc kit (2 disc universal)	5-66-8355-00							1	1	1	1	1	1	1	1	
3B	Stationary disc kit (3 disc vertical)	5-66-8356-00															
4	Friction disc kit	5-66-8462-00	1	1	1	1	1	1	1	1	1	1	1	1	1	1	1
4C	Stabilizing clip (part of 5-66-8462-00)		2	2	2	2	2	2	2	2	2	2	2	2	2	2	2
4DP	Disc pack kit (1 disc) Disc pack kit (2 disc) Disc pack kit (3 disc)	5-66-8601-00 5-66-8602-00 5-66-8603-00	1	1	1	1	1	1	1	1	1	1	1	1	1	1	1
16	Hub (5/8 bore) Hub (7/8 bore) 3 disc (7/8 bore)	5-16-5150-00-01B 5-16-5150-00-01D 5-16-5153-00-02D	1	1	1	1	1	1	1	1	1	1	1	1	1	1	1
2	Endplate assembly	1 & 2 disc (NEMA 2 & 4) 1 & 2 disc (NEMA 4X) 3 disc (NEMA 2 & 4) 3 disc (NEMA 4X)	5-02-5035-00 5-02-5039-00 5-02-5036-00 5-02-5040-00	1	1	1	1	1	1	1	1	1	1	1	1	1	1
2A	Pipe plug - external lead holes Pipe plug - stainless (ext. lead holes)	9-33-0914-00 9-33-0624-00	1	1	1	1	1	1	1	1	1	1	1	1	1	1	1

* Certain multiple friction disc model numbers require a single stabilizer clip (D1) added to each friction disc. If your particular brake model has this clip on the discs, as received, it must be replaced whenever the friction disc is replaced. This clip is included as part of the friction disc kit 5-66-8462-00.

Support Plate Assembly

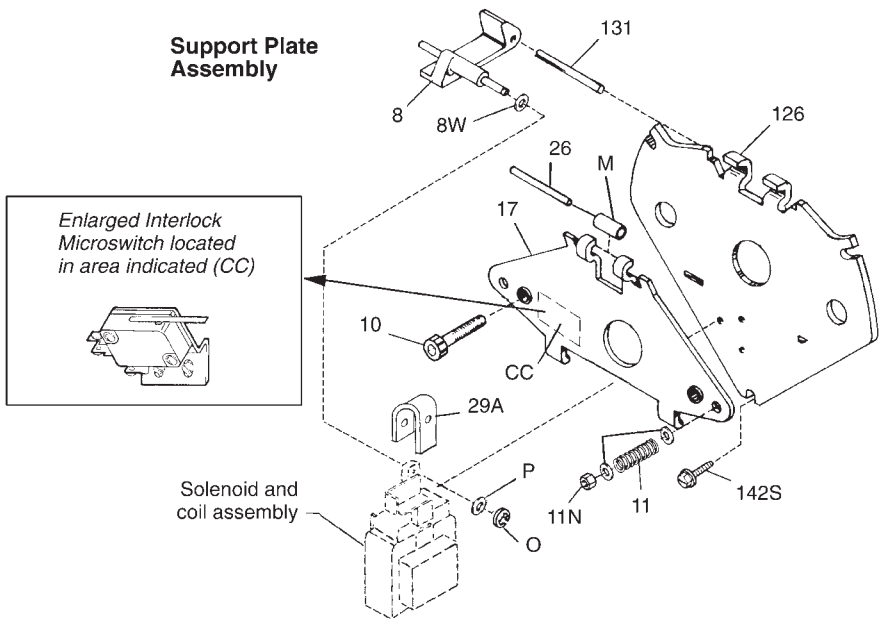

For DC coil/Solenoid parts refer to Instruction Sheet 8-078-950-00

Solenoid and Coil Assembly

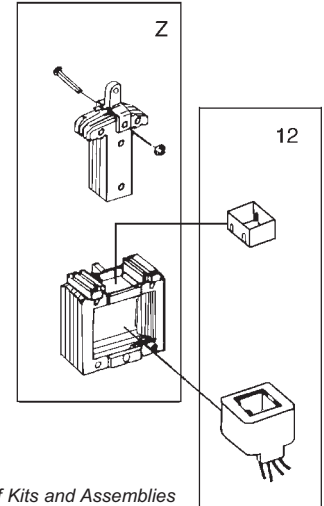

TABLE 2
Components of Support Plate and Coil Assembly

Item	Description	Part Number ↓	Torque (lb-ft)						
			1.5 & 3	6	10	15	20	25	
6	Bearing	8-006-501-00	1	1	1	1	1	1	
8	Solenoid lever	8-008-504-01	1	1	1	1	1	1	
8R	Retaining ring	9-03-0057-00	1	1	1	1	1	1	
8W	Spacer	9-45-0168-00	2	2	2	2	2	2	
11N	Torque adjustment nut	9-40-3928-00	2	2	2	2	2	2	
10	Wear adjustment screw	9-17-8420-00	2	2	2	2	2	2	
11	Pressure spring	9-70-1215-00	2						
	Pressure spring	9-70-1523-00		2					
	Pressure spring	9-70-1524-00				2	2	2	
11W	Spring washer	9-46-0010-00			4	4	4	4	
17	Lever arm and stop nut assy.	5-17-5011-00	1	1	1	1	1	1	
26	Bearing pin	9-29-4826-00	1	1	1	1	1	1	
29A	Plunger stop	8-094-503-00	1	1	1	1	1	1	
126	Support plate and spring stud assembly	5-26-5021-00	1	1	1	1	1	1	
131	Pivot pin	9-29-4836-00	1	1	1	1	1	1	
142S	Mounting screws	9-25-9013-00	3	3	3	3	3	3	
AC Brakes									
Z	No. 4 solenoid kit	5-96-5047-01	1	1	1	1	1	1	
12**	No. 4 coil kit 60 Hz	115/230 Vac	5-66-6407-33	1					
		230/460 Vac	5-66-6409-33	1					
		115 Vac	5-66-6401-33	1					
		230 Vac	5-66-6402-33	1					
		460 Vac	5-66-6404-33	1					
		575 Vac	5-66-6405-33	1					
	No. K4 coil kit 60 Hz	115/230 Vac	5-66-6457-33		1	1			
		230/460 Vac	5-66-6459-33		1	1			
		115 Vac	5-66-6451-33		1	1			
		230 Vac	5-66-6452-33		1	1			
		460 Vac	5-66-6454-33		1	1			
		575 Vac	5-66-6455-33		1	1			
	No. K4+ coil kit 60 Hz	115/230 Vac	5-66-6407-23				1	1	
		230/460 Vac	5-66-6409-23				1	1	
		115 Vac	5-66-6401-23				1	1	
		230 Vac	5-66-6402-23				1	1	
		460 Vac	5-66-6404-23				1	1	
		575 Vac	5-66-6405-23				1	1	
	No. M4+ coil kit 60 Hz	115/230 Vac	5-66-6457-23					1	
		230/460 Vac	5-66-6459-23					1	
		115 Vac	5-66-6451-23					1	
		230 Vac	5-66-6452-23					1	
		460 Vac	5-66-6454-23					1	
		575 Vac	5-66-6455-23					1	
CC	Brake release interlock switch (optional)	5-57-5526-00	1	1	1	1	1		

TABLE 3
Contents of Kits and Assemblies

Letter Designation	Kit Description
A	Coupler brake shaft kit 5/8" shaft (5-66-8865-00) 7/8" shaft (5-66-8867-00) 3 disc 7/8" shaft (5-66-8869-00) 1 – Hub and set screw assembly 1 – Ball bearing 1 – Housing retaining ring 1 – Brake shaft 1 – Brake shaft key
3	Stationary disc kit (5-66-8354-00) 1 – Stationary disc
3A	Stationary disc kit (5-66-8355-00) 2 – Stationary discs with springs
3B	Stationary disc kit (5-66-8356-00) 3 – Stationary discs with springs
4	Friction disc kit (5-66-8462-00) 1 – Friction disc 2 – Stabilizing springs (for 1-1/2-6 lb-ft brake use only)
4DP	Disc pack kit (5-66-860X-00) 1,2 or 3 – Friction disc(s) 1,2 or 3 – Stationary disc(s) 2 – Stabilizing springs (for 1-1/2-6 lb-ft brake use only) 3,6 or 9 – Stationary disc separator springs
7S	Mounting stud kit (5-96-052X-00) 4 – Mounting studs 4 – Lock washers 4 – Nuts
Z	No. 4 solenoid kit (5-96-5047-01) 1 – Plunger 1 – Solenoid link 1 – Frame (including mounting bracket) 1 – Solenoid link cap screw 1 – Solenoid link nut 3 – Solenoid mounting screws
12	No. 4 AC coil kit (5-66-64XX-X3) Coil Top Plunger guide Wire nut
CC	Brake release interlock switch (5-57-5526-00) 1 – Microswitch 1 – Mounting bracket 2 – Bracket mounting screws 2 – Switch mounting screws 2 – Lead wire assembly

Optional Modification Kits

TABLE 4

Catalog Mod Number	Description	Part Number ↓	Torque (lb-ft)		
			1.5, 3 & 6	10 & 15	20 & 25
M4	Brass Stationary Disc	8-003-513-02	1	2	3
M13	Space Heater 115 Vac 230 Vac	5-27-2004-00 5-27-2005-00	1 1	1 1	1 1
M17	Terminal Strip	5-63-0524-00	1	1	1
M21	Vertical Spring Kit (2 disc) (3 disc)	5-63-0539-00 5-63-0525-00		1	1

Catalog Mod Number	Description	Part Number ↓	Torque (lb-ft)				
			1.5 & 3	6 & 10	15 & 20	25	
M6	No. 4 Class 'H' coil kit 60 Hz	115/230 Vac	5-96-6407-05	1			
		230/460 Vac	5-96-6409-05	1			
		115 Vac	5-96-6401-05	1			
		230 Vac	5-96-6402-05	1			
		460 Vac	5-96-6404-05	1			
		575 Vac	5-96-6405-05	1			
	No. K4 Class 'H' coil kit 60 Hz	115/230 Vac	5-96-6457-05		1		
		230/460 Vac	5-96-6459-05		1		
		115 Vac	5-96-6451-05		1		
		230 Vac	5-96-6452-05		1		
		460 Vac	5-96-6454-05		1		
		575 Vac	5-96-6455-05		1		
	No. K4+ Class 'H' coil kit 60 Hz	115/230 Vac	5-96-6407-25			1	
		230/460 Vac	5-96-6409-25			1	
		115 Vac	5-96-6401-25			1	
		230 Vac	5-96-6402-25			1	
		460 Vac	5-96-6404-25			1	
		575 Vac	5-96-6405-25			1	
	No. M4+ Class 'H' coil kit 60 Hz	115/230 Vac	5-96-6457-25				1
		230/460 Vac	5-96-6459-25				1
115 Vac		5-96-6451-25				1	
230 Vac		5-96-6452-25				1	
460 Vac		5-96-6454-25				1	
575 Vac		5-96-6455-25				1	



Rexnord Industries, LLC
 Stearns Division
 5150 S. International Drive
 Cudahy, Wisconsin 53110
 (414) 272-1100 Fax: (414) 277-4364 www.stearns.rexnord.com