

## Service Instructions for No. 4 AC Solenoid Kit Series 55,700 Disc Brakes

Item No.	Description of Parts Included in Kit	Quantity per Kit
29	Solenoid plunger	1
13	Solenoid link	1
79	Solenoid frame	1
13C	Solenoid link cap screw	1
13N	Solenoid link nut	1
132	Solenoid mounting screw	3

### Important

Please read these instructions carefully before servicing your Stearns brake. Failure to comply with these instructions could cause injury to personnel and/or damage to property if the brake is installed or operated incorrectly. For definition of limited warranty/liability, contact Rexnord Industries, Inc., Stearns Division, 5150 S. International Dr., Cudahy Wisconsin 53110, (414) 272-1100.

### Caution

- Installation or servicing shall be in compliance with applicable local safety codes including Occupational Safety and Health Act (OSHA). All wiring and electrical connections must comply with the National Electric Code (NEC) and local electric codes in effect.
- To prevent an electrical hazard, disconnect power source before installing or servicing of the brake. If power disconnect point is out of sight, lock disconnect in the *off* position and tag to prevent accidental application of power.
- The exterior surface of an operating brake may be hot enough to cause injury. Allow sufficient time for the brake to cool before disassembly.
- Do not operate brake with housing removed. All moving parts should be guarded.
- After usage, the brake interior will contain burnt and degraded friction material dust. This dust must be removed before servicing or adjusting the brake.

DO NOT BLOW OFF DUST using an air hose. It is important to avoid dispersing dust into the air or inhaling it, as this may be dangerous to your health.

- Wear a filtered mask or a respirator while removing dust from the inside of a brake.
  - Use a vacuum cleaner or a soft brush to remove dust from the brake. When brushing, avoid causing the dust to become airborne. Collect the dust in a container, such as a bag, which can be sealed off.
- Installation or maintenance should be performed only by qualified personnel familiar with the construction and operation of the brake.
  - For proper performance and operation, only genuine Stearns parts should be used for repairs and replacements.

**Warning!** Any mechanism or load held in position by the brake should be secured to prevent possible injury to personnel or damage to equipment before any disassembly of the brake is attempted or before the manual release knob or lever is operated on the brake.

### Instructions

- Remove housing (7) by unscrewing nuts from the four mounting studs (128) that protrude through the reducer flange.
- Grasp the coupler brake and motor as a unit and pull free from the reducer.
- Pull housing from the mounting studs (128). These studs are threaded into the C-face and should remain in place.
- Solenoid replacement can be accomplished without removing the support plate from the brake.
- Disconnect coil lead wires. Remove three solenoid mounting screws (132) to free solenoid frame (79). Note mounting position.

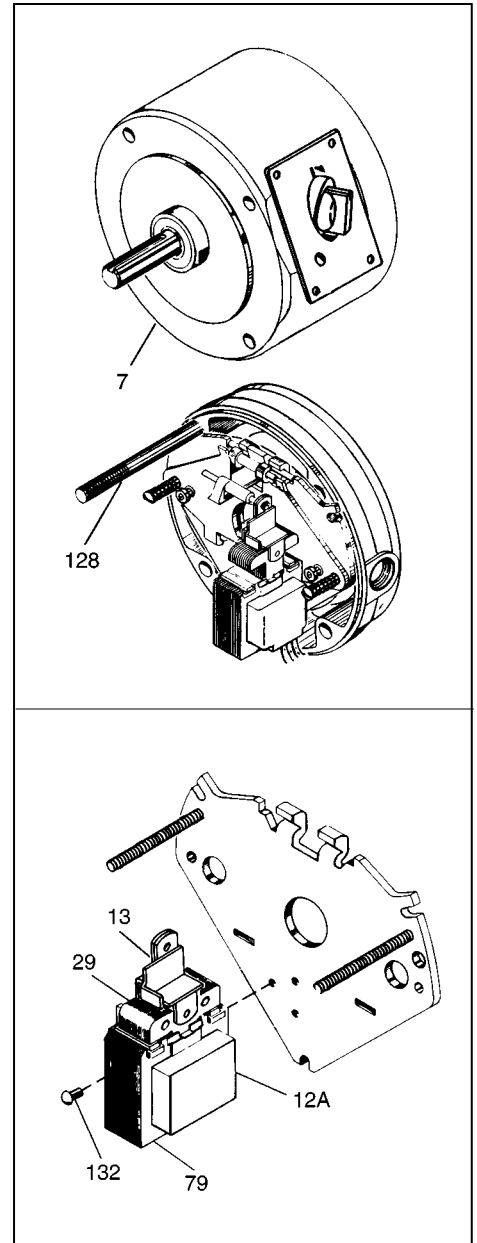

6. Disconnect solenoid plunger (29) and solenoid link (13) as an assembly and discard.
7. To remove coil (12A) unscrew plunger guide screw (84) and lock washer (84W). Remove both plunger guides (82) by prying up on the flanges.
  - a) To remove coil (12B) lift plunger guide (82A) out of top of solenoid frame (79). To remove coil (12B) from solenoid frame (79), depress lock tab at opposite lead wire side of coil and slide coil sideways from frame.

**Note:** If coil has burned out, be sure to remove all foreign material from solenoid plunger (29) and solenoid frame (79).

11. The solenoid air gap may be decreased by turning both wear adjustment screws (10) equal amounts clockwise, approximately 1/8 turn, until approximate solenoid gap is attained. Counterclockwise rotation will increase gap.

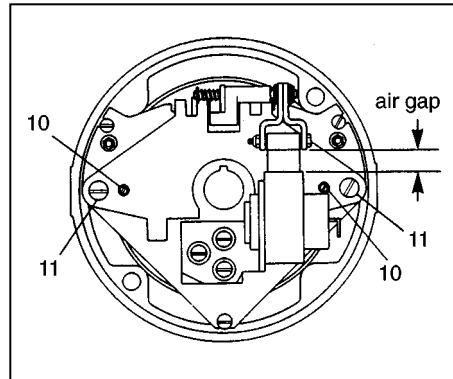

8. Install coil (12A) or (12B) in reverse order of 5 or 5a. Be sure that coil is installed in solenoid frame in same position and lock tab on coil (12B) latches on solenoid frame.
9. Join new link (13) with cap screw (13C) and nut (13N) to plunger (29). Reinstall link to pin with spacers and retaining ring. Mount frame (79) (with plunger installed) with screws (132) in same mounting position as removed. Torque screws to 43 in-lbs after aligning frame and plunger.
10. Manually lift solenoid plunger to maximum travel. Depress and allow solenoid plunger to snap out several times. Measure solenoid air gap between mating surfaces of solenoid frame and solenoid plunger. (On vertically mounted brakes, it will be necessary to push solenoid plunger into solenoid frame to the point where spring pressure is felt, before measuring solenoid air gap.)

12. Reconnect solenoid coil leads.
13. Replace housing (and housing nuts) in reverse order of the appropriate point in step 1.
14. **Caution!** Do not run motor with brake in manual release position. It is intended only for emergency manual movement of the driven load, not as a substitute for full electrical release.

**NOTE: For complete instructions, with troubleshooting, request sheet applicable to the series of brake that you have.**

If solenoid air gap exceeds gap in Table, adjustment is suggested.

The solenoid air gap measurements are shown in Table below.

**Table: Solenoid air gap measurements**

Nominal Static Torque (lb-ft)	55,700
1.5, 3	13/32
6	1/2
10	1/2
15	9/16

