

## Service Instructions for Vertical Mounting

### Series 87,000; 87,100; 87,200; 87,400, 87,500 and 87,700 (rev. B)

Spring arrangement for vertical mounting above motor for standard friction discs with cast iron pressure plate and stationary disc(s). For other combinations of material consult factory.

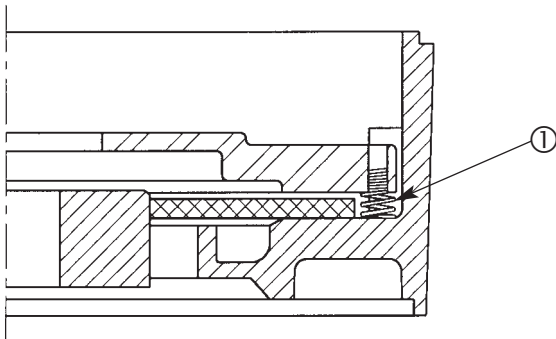

#### 1 Friction Disc – Vertical Above

Item No.	No. Req.	Part Number	Description
1	3	9-70-1118-00	Blue Vertical Push-in Spring

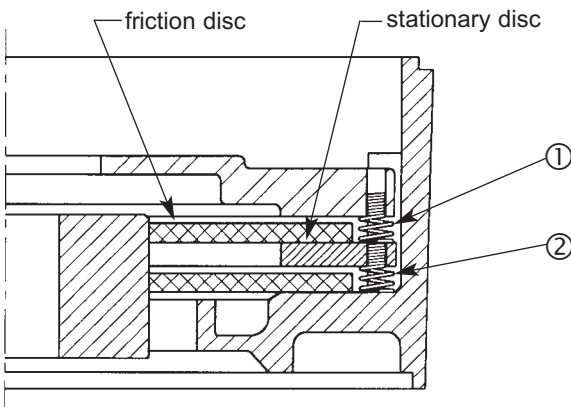

#### 2 Friction Discs – Vertical Above

Item No.	No. Req.	Part Number	Description
1	3	9-70-1115-00	Plain Vertical Push-in Spring
2	3	9-70-1119-00	Red Vertical Push-in Spring

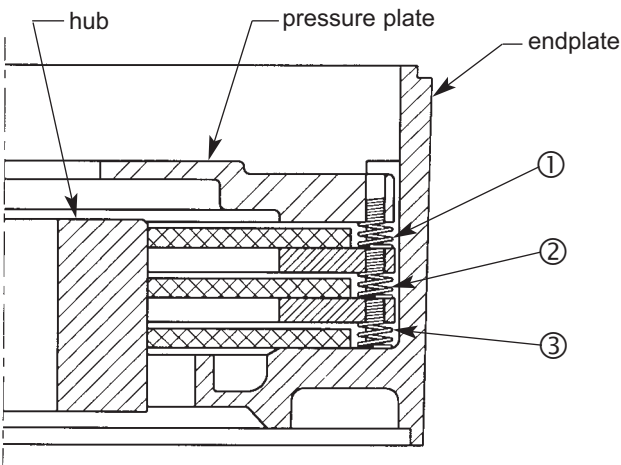

#### 3 Friction Discs – Vertical Above

Item No.	No. Req.	Part Number	Description
1	3	9-70-1118-00	Blue Vertical Push-in Spring
2	3	9-70-1115-00	Plain Vertical Push-in Spring
3	3	9-70-1119-00	Red Vertical Push-in Spring

#### NOTES:

- Follow installation and service instruction sheet P/N 8-078-928-01 for assembly of brake to motor.
- Insert identically colored springs into the stationary disc/pressure plate as it pertains to the number of disc(s) in your brake. (Example: For two friction discs vertical below, always use the red springs in the pressure plate.)

**Note 1:** Insert spring by turning clockwise until large coil diameter bottoms against the stationary disc/pressure plate.

**Note 2:** Reassemble the disc pack with the stationary discs/pressure plate in the proper arrangement shown above. Always insert stationary disc/pressure plate with the spring side toward the motor.

- For part numbers of endplate, stationary disc and pressure plate, refer to parts list sheet for your specific brake.

**Caution!** Brakes with carrier discs cannot be used in a vertical orientation due to the weight of the disc.

Spring arrangement for vertical mounting below motor for standard friction discs and cast iron stationary disc(s). For other combinations of material consult factory.

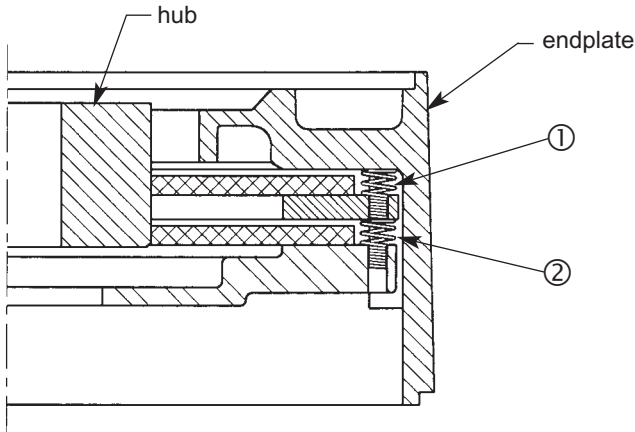

**2 Friction Discs – Vertical Below**

Item No.	No. Req.	Part Number	Description
1	3	9-70-1118-00	Blue Vertical Push-in Spring
2	3	9-70-1119-00	Red Vertical Push-in Spring

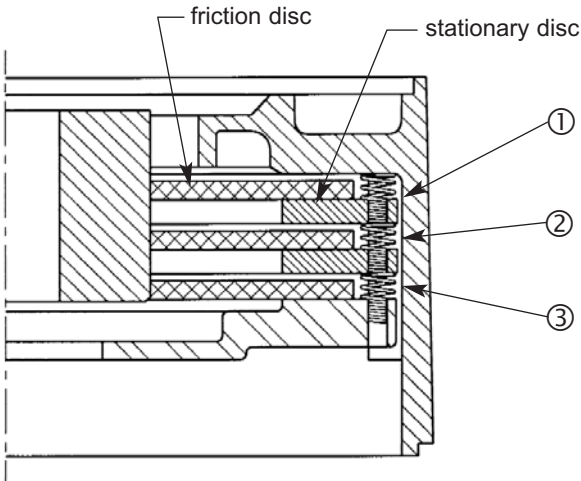

**3 Friction Discs – Vertical Below**

Item No.	No. Req.	Part Number	Description
1	3	9-70-1118-00	Blue Vertical Push-in Spring
2	3	9-70-1119-00	Red Vertical Push-in Spring
3	3	9-70-1116-00	Purple Vertical Push-in Spring

**NOTES:**

1. Follow installation and service instruction sheet P/N 8-078-928-01 for assembly of brake to motor.
2. Insert identically colored springs into the stationary disc/pressure plate as it pertains to the number of disc(s) in your brake. (Example: For two friction discs vertical below, always use the red springs in the pressure plate.)

**Note 1:** Insert spring by turning clockwise until large coil diameter bottoms against the stationary disc/pressure plate.

**Note 2:** Reassemble the disc pack with the stationary discs/pressure plate in the proper arrangement shown above.

- Always insert stationary disc/pressure plate with the spring side toward the motor.
  - 3. For part numbers of endplate, stationary disc and pressure plate, refer to parts list sheet for your specific brake.
  - 4. Brakes with a single friction disc do not require a modification for vertical mounting below.
- Caution!** Brakes with carrier discs cannot be used in a vertical orientation due to the weight of the disc.

