

Installation, Service and Parts List Series 56,800 for Class I & II, Division 2 Manual Adjust Brakes Rev: C

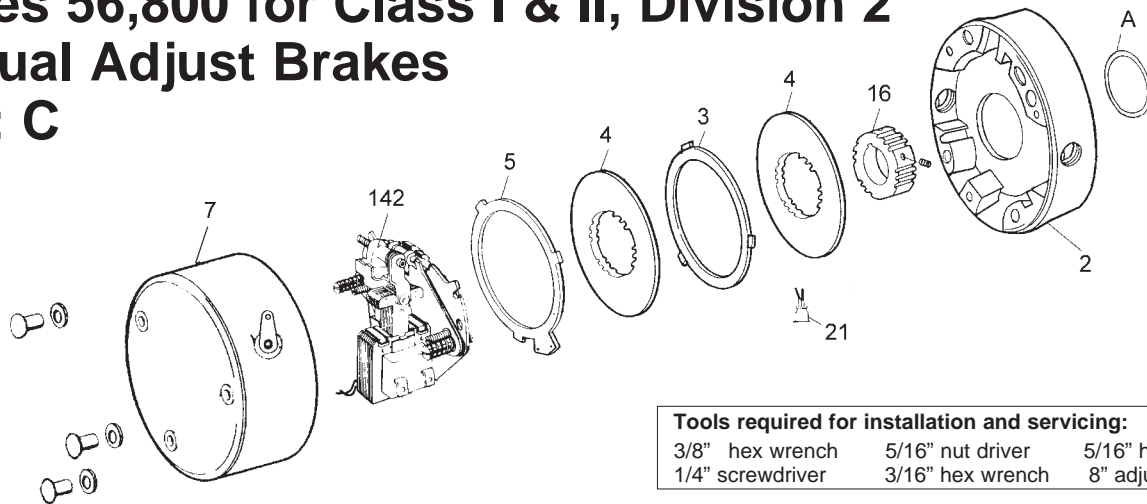

Tools required for installation and servicing:

3/8" hex wrench	5/16" nut driver	5/16" hex wrench
1/4" screwdriver	3/16" hex wrench	8" adjustable wrench

Typical Nameplate

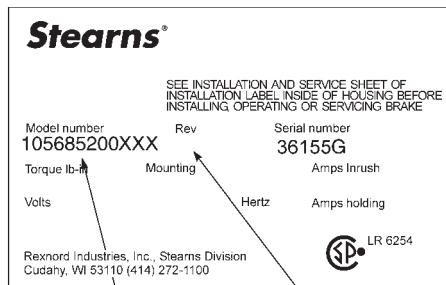

MODEL NUMBER
Refer to actual nameplate on
brake for additional information

REVISION CONTROL
(if applicable) and
Brake Serial Number

IMPORTANT

Please read these instructions carefully before installing, operating, or servicing your Stearns Brake. Failure to comply with these instructions could cause injury to personnel and/or damage to property if the brake is installed or operated incorrectly. For definition of limited warranty/liability, contact Rexnord Industries, LLC, Stearns Division, 5150 S. International Dr., Cudahy, WI 53110, (414) 272-1100.

Caution

1. Installation and servicing must be made in compliance with all local safety codes including Occupational Safety and Health Act (OSHA). All wiring and electrical connections must comply with the National Electric Code (NEC) and local electric codes in effect. For additional information refer to the Underwriters Laboratory (UL) website at: <http://www.ul.com/hazloc/codes.html>
2. This brake may not be suitable for use in certain atmospheres containing explosive gases and dusts. **HazLoc** inspection authorities are responsible for verifying and authorizing the use of suitably designed and installed **HazLoc** equipment. When questions arise consult local Authority Having Jurisdiction (**AHJ**).
3. To prevent an electrical hazard, disconnect power source before working on the brake. If power disconnect point is out of sight, lock disconnect in the *off* position and tag to prevent accidental application of power.

4. Make certain power source conforms to the requirements specified on the brake nameplate.
5. Be careful when touching the exterior of an operating brake. Allow sufficient time for brake to cool before disassembly. Surfaces may be hot enough to be painful or cause injury.
6. Do not operate brake with housing removed. All moving parts should be guarded.
7. Installation and servicing should be performed only by qualified personnel familiar with the construction and operation of the brake.
8. For proper performance and operation, only genuine Stearns parts should be used for repairs and replacements.
9. After usage, the brake interior will contain burnt and degraded friction material dust. This dust must be removed before servicing or adjusting the brake.

DO NOT BLOW OFF DUST using an air hose. It is important to avoid dispersing dust into the air or inhaling it, as this may be dangerous to your health.

- a) Wear a filtered mask or a respirator while removing dust from the inside of a brake.
- b) Use a vacuum cleaner or a soft brush to remove dust from the brake. When brushing, avoid causing the dust to become airborne. Collect the dust in a container, such as a bag, which can be sealed off.

General Description

This brake series is spring-set, electrically released. It contains one or more rotating friction discs (4) driven by a hub (16) mounted on the motor or other shaft.

The brake is Listed by Underwriters Laboratories, Incorporated for Division 2 - normally not hazardous location. The Class and Group designation is shown on nameplate. The listing includes brakes for attachment to TENV or TEFC motor.

The listing marks on the brake apply only to the brake, not to the driving equipment. In the case of another mounted brake, neither brake nor motor are Listed unless both are Listed. The listing marks of both the brake and the motor

must be in agreement as to the Class and Group rating.

Note: Fanguard-mounted brakes requiring IP54 & IP55 protection may require additional sealing measures beyond seals provided with this brake. Pressurized sprays aimed at the fan and brake hub surfaces can result in fluid migration along the motor shaft and keyway, and into the brake. The use of an appropriate sealant, such as *RTV*, or a *forsheda* seal is advised.

Operating Principle

This brake series contains two or three friction discs (4) assembled alternately between the endplate (2) friction surface, stationary disc(s) (3) and pressure plate (5). The stationary discs are restrained from rotating by being keyed into the endplate. With the brake released, all disc pack components are free to slide axially and the friction discs to rotate.

Brake release occurs when the solenoid coil is electrically energized, causing the solenoid plunger to travel a specified distance and through a lever system, overcoming the pressure spring force. This action releases the clamping force on the disc pack, thereby allowing the friction discs and brake hub to rotate.

Brake sets and torque is produced when electric current to the solenoid coil is interrupted, thereby collapsing the solenoid magnetic field. The solenoid plunger returns to its original de-energized position allowing the lever arm to move forward by virtue of the compressed torque springs. This action compresses the disc pack components which applies a retarding torque to the brake hub and ultimately restores the brake to a spring-set static condition.

Caution 1: While the brake is equipped with a manual release to allow manual shaft rotation, the motor should not be run with the manual release engaged, to avoid overheating the friction discs.

Caution 2: Do not operate manual release until brake is installed to preserve alignment of friction discs for ease of brake assembly.

BRAKE MOUNTING (Manual Adjust)

1 Place hub on motor shaft.

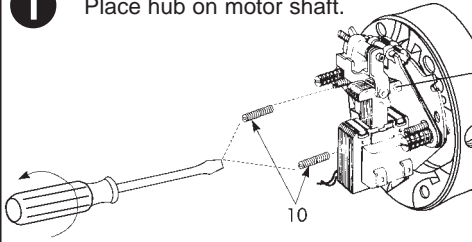

2 Position hub on shaft as shown.

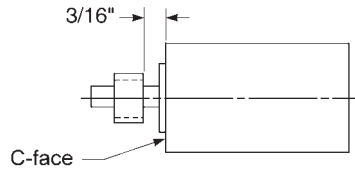

3 Tighten set screws to motor shaft.

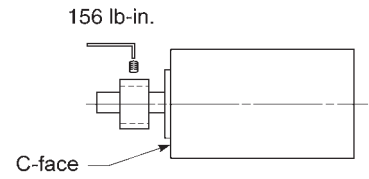

4 Remove brake housing and gasket.

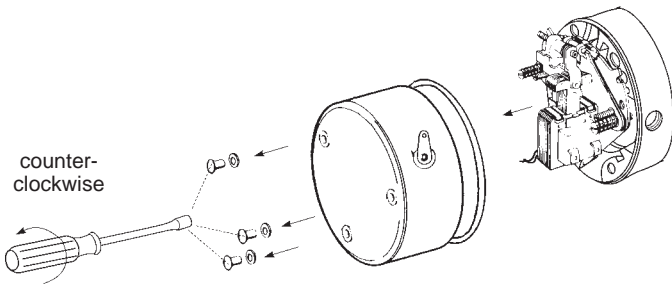

5 Slide endplate over hub noting position of stabilizer springs, if used. (Refer to Friction Disc Replacement, View 4 and 4A.)

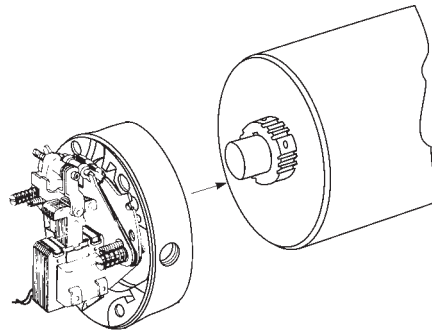

6 Mount brake endplate to motor C-face.

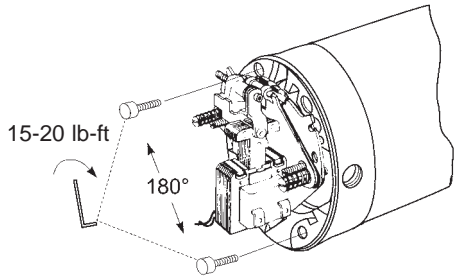

* For vertical assembly of 20 & 25 lb-ft brakes, refer to page 5.

7 Connect coil leadwires to power supply. Refer to nameplate for voltage rating.*
Caution: Keep wiring away from pinch points and moving components.

Coil Wiring

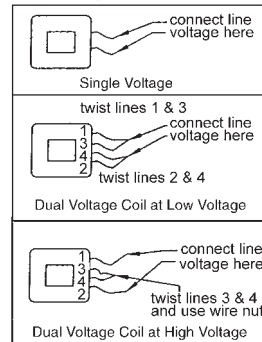

* Refer to Figure 7 (page 5) for control circuit wiring.

8 Replace brake housing and gasket and tighten to 12 lb-in.

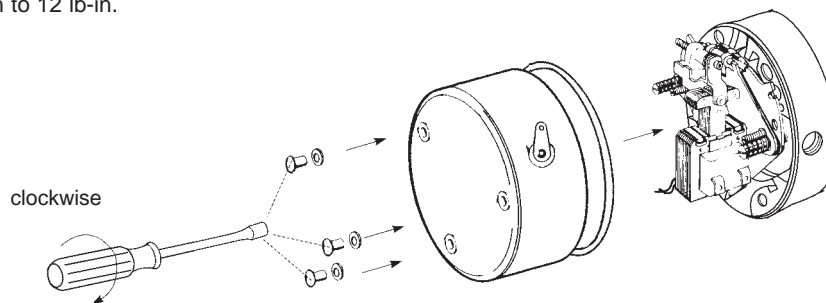

AIR GAP ADJUSTMENT

Series 56,800

As friction discs wear the air gap will increase. When plunger gets to the reset position, the air gap must be adjusted.

- 1** To **increase** air gap, turn adjusting screw (10) counterclockwise.

56,800 Series Air Gap* (Rev C)

Disc	Torque	Min/Max
2	3, 6, 10 & 15	.45" - .69"
3	20 & 25	.50" - .69"

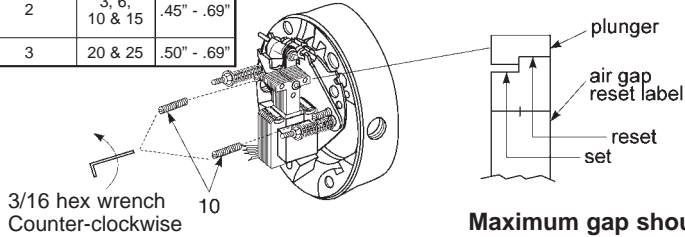

- 2** To **decrease** air gap, turn adjusting screw (10) clockwise.

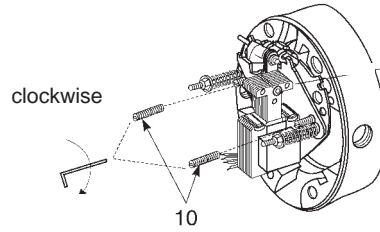

Maximum gap should never exceed .69"

FRICTION DISC REPLACEMENT

Series 56,800

- 1** Remove brake housing and gasket.

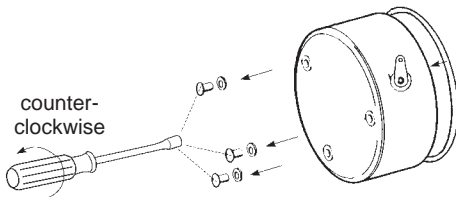

- 2** Remove support plate screws and lift support from brake.

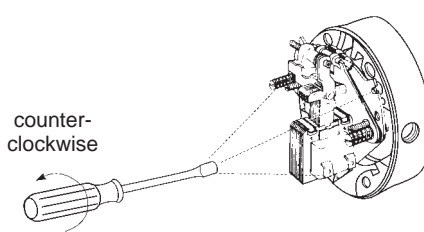

- 3** Remove and discard old friction disc.

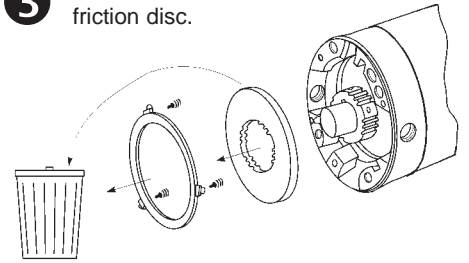

- 4** Install new friction disc(s) and stationary disc(s) as shown.

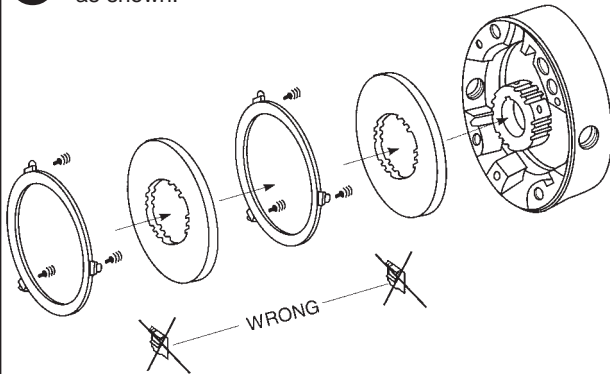

Note:

- Multiple disc brakes do not use stabilizer clips
- Refer to page 5 for separator spring orientation

- 5** Reposition support plate on endplate and tighten mounting screws to 55 lb-in.

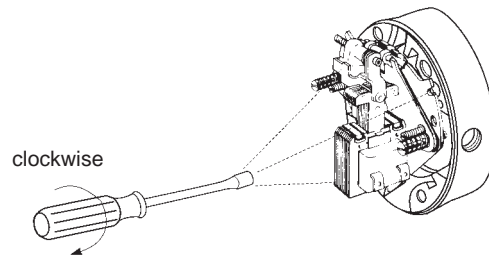

- 6** Reposition housing and tighten nuts to 12 lb-in.

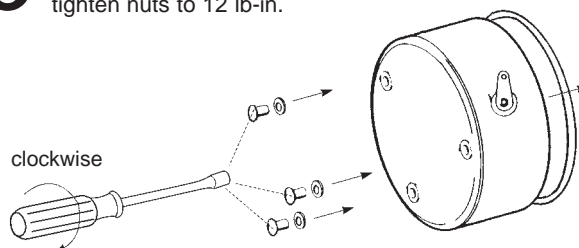

COIL REPLACEMENT

Series 56,800

1 Remove brake housing.

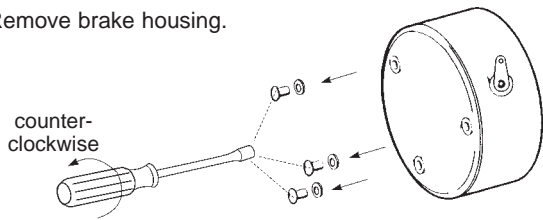

2 Disconnect coil leadwires from power source.

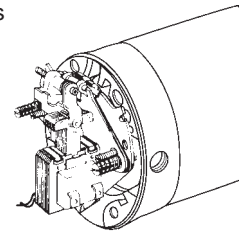

3 Insert screwdriver between support plate and lever arm and pry forward.

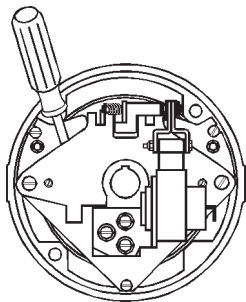

4 Lift plunger/solenoid lever assembly out of coil.

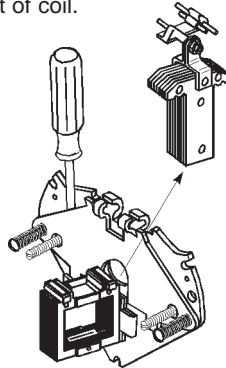

5 Remove plunger guide.

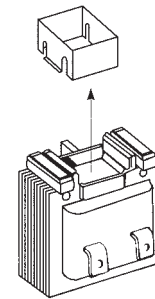

6 Discard coil.

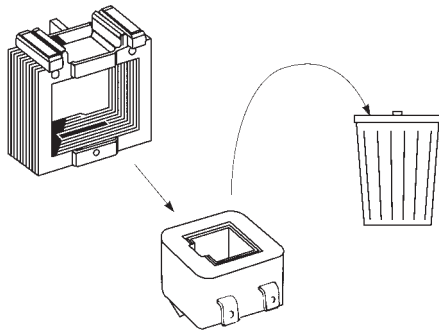

7 A) Insert new coil. (Lead wires in same position as old coil.)
B) Insert plunger guide.

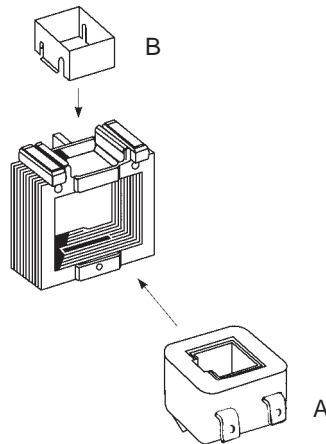

8 A) Reinsert plunger into coil; drop pivot pin into cradle of support plate.
B) Remove screwdriver.

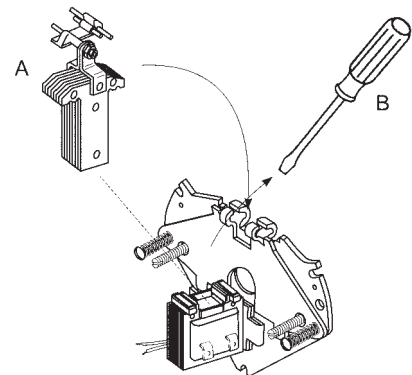

9 Reconnect coil leadwires to power source.

Coil Wiring

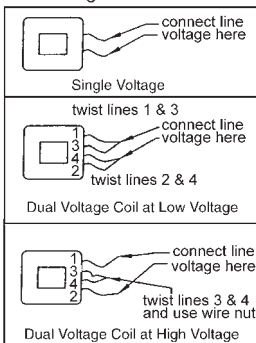

10 Reassemble housing. Tighten to 12 lb-in.

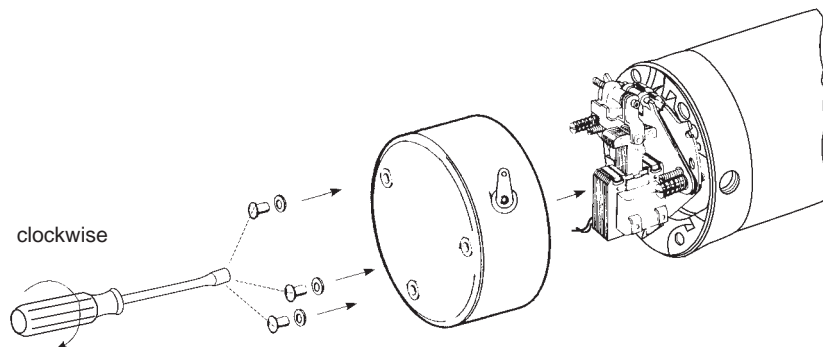

Vertical Brake Assembly

Double disc brakes (3, 6, 10 & 15 lb.-ft.) universal mount but require separator springs which are preassembled to the stationary disc. These discs are inserted spring first into the brake. Refer to figure 5A below.

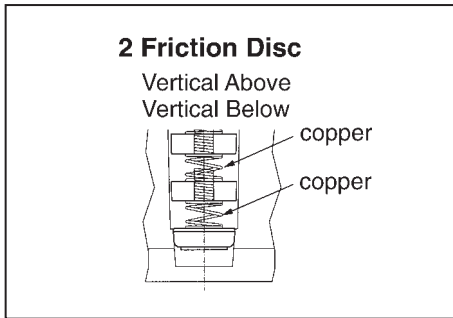

Figure 5A

Installation Procedure for 20 and 25 lb-ft brakes if mounted vertical to motor shaft (These brakes are factory assembled for horizontal operation.)

Remove support plate by loosening the three mounting screws.

Remove stationary discs and friction discs.

Using the spring kit provided with this brake, insert three springs of identical color into each stationary disc hole. Springs are inserted from the side opposite the indent mark (see Figure 5B). Stationary disc should be placed on a clean flat surface with a clearance hole to allow the tip of the spring to extend through the bottom side of the stationary disc. Using the 1/8" pin provided and a hammer, drive the hold until the large coil diameter bottoms out against the disc.

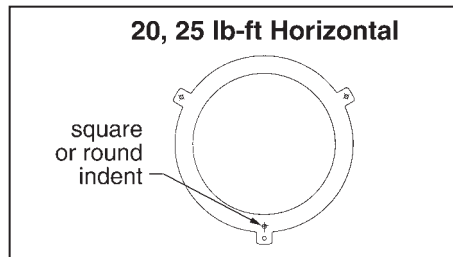

Figure 5B

Reassemble the disc pack with the stationary discs in the proper arrangement shown in Figure 5C. Mount support plate and torque screws evenly to 55 in-lbs.

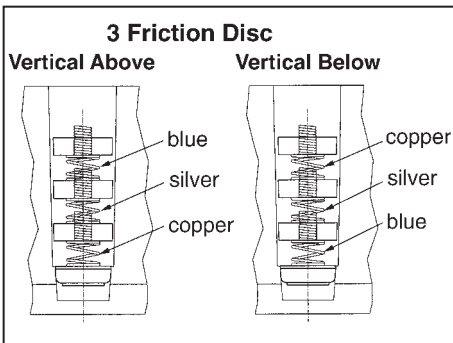

Figure 5C

Torque Adjustment

Brake is factory set for nominal rated static torque which is maximum torque. Torque may be decreased up to 50% for increased stopping times up to 2 second stop time.

The torque on the 3 lb-ft brake may not be reduced.

Turn both adjustment nuts (11), Figure 6, equal amounts counterclockwise to decrease torque. See Table A for torque reduction permissible amounts.

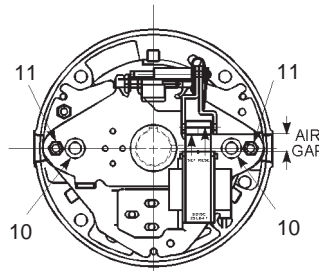

Figure 6

TABLE A

Nominal Static Torque (lb-ft)	Original Spring Height (inches)	Maximum Counterclockwise Turns	% Torque Reduction per Turn
1.5	1.69	---	---
3	1.69	---	---
6	1.69	5-1/2	9%
10	1.53		
15	1.53		
20	1.53		
25	1.47		

General Maintenance

Warning! Any mechanism or load held in position by the brake should be secured to prevent possible injury to personnel or damage to equipment before any disassembly of the brake is attempted or before the manual release knob is operated on the brake.

Observe all cautions listed at the beginning of this manual before attempting to service brake.

WARNING
The thermal protector TSW2 (21A) mounted in this brake must be wired into control circuit to limit the brake internal surface temperature.

TSW2 will open motor circuit and cause brake to engage. In extremely moist atmospheres a heater is recommended and should remain energized continually.

Rating TSW2

125 VA
Hi-pot Test
Voltage 1250 Maximum

TYPICAL CONNECTION DIAGRAM

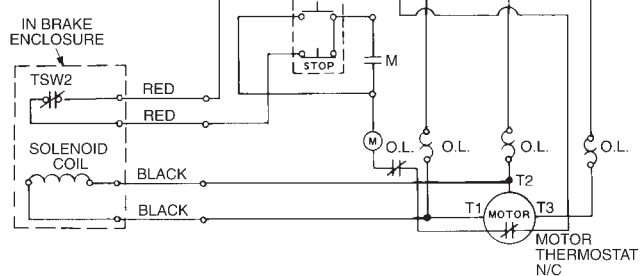

For information on dynamic torque and calculation of thermal capacity in use, refer to Application Engineering Section of Catalog 200 (Stearns Spring-Set Disc Brakes.)

Troubleshooting

A. If brake does not stop properly or overheats, check the following:

1. Are friction discs excessively worn, charred, or broken?
2. Hub may have become loose and shifted on shaft. Recheck set screw torque. Reposition hub if shifted.
3. With brake de-energized and housing (7) removed, check compressed length of pressure springs (11). Compare to Table values (at right) and adjust to minimum height to obtain desired stop times.
4. Is solenoid air gap adjusted correctly? See Page 3 for instructions.
5. Solenoid may not be energizing and releasing the brake. Check voltage at the coil and compare to the coil and/or nameplate voltage rating.
6. Check linkage for binding. Depress solenoid plunger down to frame surface. Movement to be without binding.
7. Brake coil should be energized at same time or prior to energization of motor, and de-energized at same time or after de-energization of motor.
8. Replace friction disc(s) when worn area is one half of original thickness.
9. Check to be sure wear adjust screws are of equal height. Measure from inboard side of support plate with depth micrometer. Turn one screw to obtain equal height.

B. If solenoid hums, pulls in slowly, or coil burns out, check the following:

1. Solenoid plunger to frame contact surface may be excessively dented.
2. Are solenoid plunger to frame contact surfaces sticky and dirty.
3. Solenoid mounting screws may have become loose, causing frame to shift and plunger to seat improperly.

Information required when ordering replacement parts:

- Give Part Number of parts or kits needed, Brake Model Number, and Brake Serial Number. The Brake Model and Serial Number may identify special brakes not covered by this parts list.
- When ordering hubs, specify shaft diameter (hub bore) and keyway.

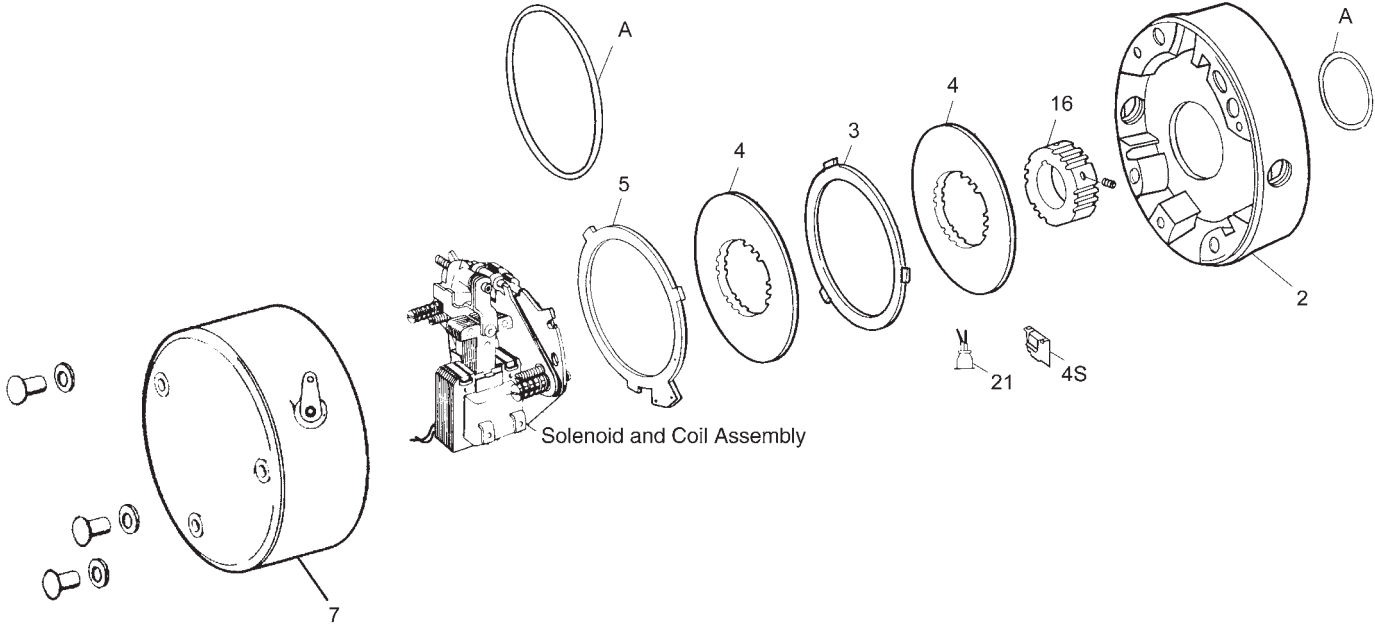
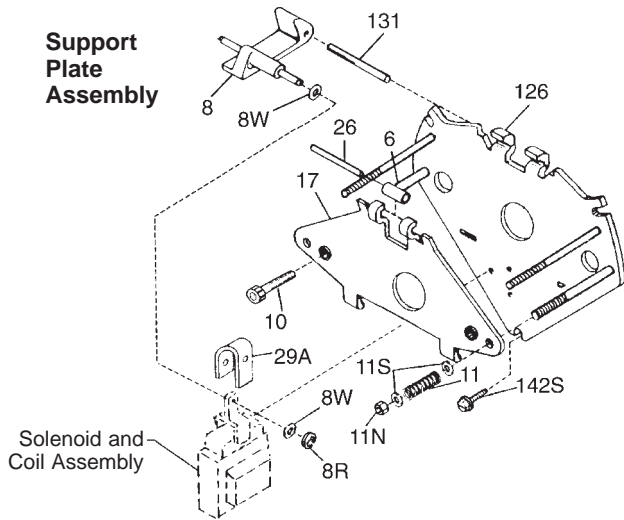
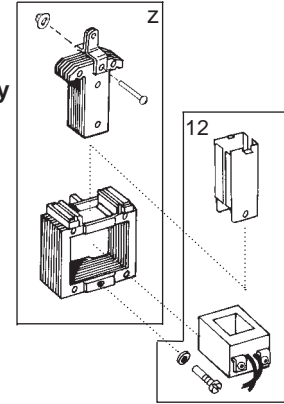

TABLE 1
Components of Standard Brake

			Torque (lb-ft)						
			1.5	3	6	10	15	20 and 25	
			Brake Model Number →						
			1-056-802-00	1-056-812-00	1-056-822-00	1-056-832-00	1-056-842-00	1-056-852-00 & 862-00	
Item	Description	Part Number ↓							
A	Hardware Kit - Side Release	5-66-1015-00	1	1	1	1	1	1	
Not Shown	Plug/Gasket kit - NEMA 4	5-63-0532-00	1	1	1	1	1	1	
	Plug/Gasket kit - NEMA 4 (3 disc)	5-63-0534-00						1	
7	Housing - Side Release	5-07-5050-00	1	1	1	1	1	1	
	Pressure plate (universal mount)	8-003-515-00	1	1	1	1	1	1	
	Stationary disc kit (universal mount)	5-66-8354-00		1	1	1	1	2	
Not Shown	Vertical spring kit	5-63-0525-00						1	
4	Friction disc kit	5-66-8462-00	1	2	2	2	2	2	
21	Thermostat	9-62-8026-00	1	1	1	1	1	1	
16	Hub and set screw assembly (2 & 3 disc)	5/8 bore	5-16-5153-00-01B	1	1	1	1	1	1
		7/8 bore	5-16-5153-00-01D		1	1	1	1	1
		1-1/8 bore	5-16-5153-00-01E		1	1	1	1	1
2	Endplate & seal assembly	1 disc	5-02-5049-00	1					
		2 & 3 disc	5-02-5050-00		1	1	1	1	1



Solenoid and Coil Assembly



**TABLE 2
Components of Support Plate and Coil Assembly**

Item	Description	Part Number ↓	Torque (lb-ft)					
			1.5 & 3	6	10	15 & 20	25	
Support Plate Assembly (items 6 through 131) →			5-42-5601-00-34	5-42-5605-00-34	5-42-5607-00-34	5-42-5609-00-34	5-42-5611-00-34	
6	Bearing	8-006-501-00	1	1	1	1	1	
8	Solenoid Lever	8-008-504-01	1	1	1	1	1	
8R	Retaining Ring	9-03-0057-00	1	1	1	1	1	
8W	Spacer	9-45-0168-00	2	2	2	2	2	
11N	Torque Adjustment Nut	9-40-3928-00	2	2	2	2	2	
10	Torque Adjustment Screw	9-17-8420-00	2	2	2	2	2	
11	Pressure Spring	9-70-1215-00	2					
	Pressure Spring	9-70-1523-00		2	2			
	Pressure Spring	9-70-1524-00				2	2	
11S	Spring Washer	9-46-0010-00		4	4	4	4	
17	Lever Arm & Stop Nut Assembly	5-17-5011-00	1	1	1	1	1	
26	Bearing Pin	9-29-4826-00	1	1	1	1	1	
29A	Plunger Stop	8-094-503-00	1	1	1	1	1	
126	Support Plate & Spring Stud Assembly (3 housing studs)	5-26-5020-00	1	1	1	1	1	
131	Pivot Pin	9-29-4836-00	1	1	1	1	1	
142S	Mounting Screws	9-25-9013-00	3	3	3	3	3	
Z	No. 4 Solenoid Kit	5-96-5047-01	1	1	1	1	1	
12	No. 4 Coil Kit 60 Hz	115/230 Vac	5-96-6407-05	1	1			
		230/460 Vac	5-96-6409-05	1	1			
		115 Vac	5-96-6401-05	1	1			
		230 Vac	5-96-6402-05	1	1			
		460 Vac	5-96-6404-05	1	1			
	575 Vac	5-96-6405-05	1	1				
	No. K4 Coil Kit 60 Hz	115/230 Vac	5-96-6457-05			1		
		230/460 Vac	5-96-6459-05			1		
		115 Vac	5-96-6451-05			1		
		230 Vac	5-96-6452-05			1		
		460 Vac	5-96-6454-05			1		
	575 Vac	5-96-6455-05			1			
	No. K4+ Coil Kit 60 Hz	115/230 Vac	5-96-6407-25				1	
		230/460 Vac	5-96-6409-25				1	
		115 Vac	5-96-6401-25				1	
		230 Vac	5-96-6402-25				1	
		460 Vac	5-96-6404-25				1	
	575 Vac	5-96-6405-25				1		
	No. M4+ Coil Kit 60 Hz	115/230 Vac	5-96-6457-25					1
		230/460 Vac	5-96-6459-25					1
115 Vac		5-96-6451-25					1	
230 Vac		5-96-6452-25					1	
460 Vac		5-96-6454-25					1	
575 Vac	5-96-6455-25					1		

**TABLE 3
Contents of Kits and Assemblies**

Item	Kit Description
A	Hardware Kit - NEMA 4 (5-66-101X-00) 1 - Endplate oil seal 1 - Drain plug 3 - Housing nuts 3 - Housing nut seal washers 2 - Endplate conduit pipe plugs 1 - Housing-to-endplate gasket
3	Stationary disc kit (5-66-8354-00) 1 - Stationary disc
4	Friction disc kit (5-66-8462-00) 1 - Friction disc 2 - Stabilizing springs
16	Hub and screw assembly - all bores, (5-16-5153-00) 1 - Brake hub 2 - Set screws
Z	No. 4 solenoid kit (5-96-5047-01) 1 - Plunger 1 - Solenoid link 1 - Frame (including mounting bracket) 1 - Solenoid link cap screw 1 - Solenoid link nut 3 - Solenoid mounting screws
12	No. 4 AC coil kit (5-96-64XX-X5) and Coil Plunger guide / Wire nut



*Rexnord Industries, LLC
Stearns Division
5150 S. International Drive
Cudahy, Wisconsin 53110
(414) 272-1100 Fax: (414) 277-4364 www.stearns.rexnord.com*