

Installation, Service Instructions and Parts List for TENV/IP54 Electromagnetic Super-Mod® and Tor-ac[□] Super-Mod® Power Applied C-Face Products

Sizes 50 / 100 / 180

SM 1040 Clutch & SM 1020 Clutch Brake
SM 3040 Clutch & SM 2030 Clutch Brake
SM 20 & SM 20MB Power On Brake

Important

Please read these instructions carefully before installing, operating, or servicing your Stearns clutch, brake or clutch-brake. Failure to comply with these instructions could cause injury to personnel and/or damage to property if the unit is installed or operated incorrectly. For definition of limited warranty/liability, contact Rexnord Industries, LLC., Stearns Division, 5150 S. International Dr., Cudahy, Wisconsin 53110, (414) 272-1100.

OEM's and subsystem suppliers, please forward these instructions with your components to the final user.

Caution

1. Servicing shall be in compliance with applicable local safety codes including Occupational Safety and Health Act (OSHA). All wiring and electrical connections must comply with the National Electric Code (NEC) and local electric codes in effect.
2. To prevent an electrical hazard, disconnect power source before working on the clutch, brake or clutch-brake. If power disconnect point is out of sight, lock disconnect in the *off* position and tag to prevent accidental application of power.
3. Be careful when touching the exterior of an operating unit. Allow sufficient time to cool before disassembly. Surface may be hot enough to be painful or cause injury.

General Information

The Super-Mod (SM) clutch, clutch brakes and power on brakes are designed to NEMA dimensional standards for C-face mount. All SM products are power on operation when nameplate rated voltage is applied separately to the clutch or brake coil. The internal SM product auto gap feature maintains a consistent de-energized armature to magnet body pole face air gap. Product can be factory ordered without the auto gap feature for soft start-stop operation with under-voltage energization of the coil. All SM's are:

- Dry operation, do not lubricate internally. Anti-seize compound can be used on the output shaft to aid in assembly and disassembly.
- Factory burnished. Unit torque will fully develop after the first 30-50 load cycles.

Overhung load limit is 85 lbs.

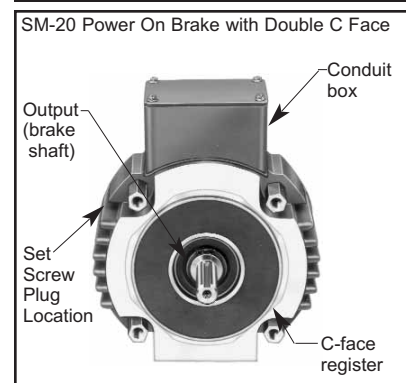
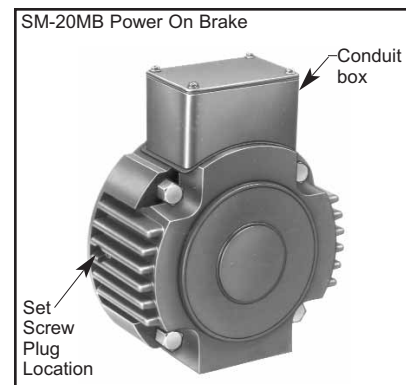
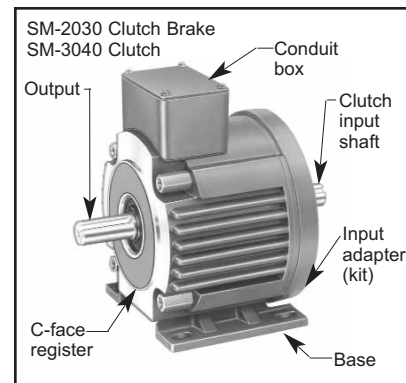
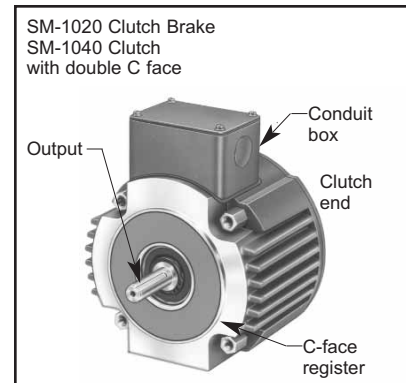

Installation Information

The SM product is installed as an assembly.

1. The SM product is supplied with a grooved machine key pressed into the drive hub bore. Confirm the key is in place. Do not force the key forward during installation.
2. Setscrews should be backed out until after installation on the motor shaft.
3. Check the mount C-face register for burrs or knicks that would prevent an aligned close fit.
4. Position and align the SM product to slide the drive hub onto the motor shaft. Do not use force. If the hub does not readily slide into position, check shaft straightness, finish and diameter. If necessary polish the shaft or keyway for a smooth close slip fit.
5. After C-face mount, the four supplied bolts are alternately finger tightened then apply torque to:
25 lb-ft for coupler mount or
38 lb-ft for SM20MB (only)
6. Tighten the two hub setscrews to 150 lb-in by fully inserting the allen key / hex wrench into the setscrews. The setscrews can be reached by removing the access plug and rotating the shaft. One setscrew locates over the key, the second a ¼ rotation, or 90 degrees, away.
7. Re-install the set screw plug.
8. After SM mount, coupler assemblies can be mounted to a C-face gear reducer.
9. Maximum overhung load capacity for the shaft is 85 lbs. Overhung capacity is based on ISO standards at 50,000 hours continuous operation at 1750 rpm with force ½" (13mm) from end of shaft.
10. Repeat steps 3 & 4 above during reducer mount. Torque reducer mount bolts to the manufacturers' specifications.

Electrical Connections:

1. Brake coil leads are red.
2. Clutch coil leads are black.
3. Coil voltage is printed on the nameplate.
4. Many 115 VAC full wave rectifier controls operate with 103 VDC output. This is not harmful to the SM 90-100 VDC coil.
5. Except for Torac module rectifiers, rectified voltage control voltage should be switched on the DC line side. Refer to specific manufacturer recommendations for proper wiring.
6. Power is switched between the clutch and brake coils in clutch-brake unit.

Torac™ Module Rectification:

1. The solid state construction Torac module includes a full wave rectifier with varistor and transistor for rapid AC side switching when used with the SM product.
2. Torac™ rectifiers are used with 90 VDC coils and do not have a polarity requirement.
3. One torac module is used with each coil. A clutch brake requires two Torac rectifiers. A clutch only or brake only uses one torac module.
4. The torac module can be used at 50 or 60 hz. The 115 VAC torac is rated 105-125VAC. The 230VAC torac is rated 208-240VAC.
5. The 115 VAC torac module has a full wave 100VDC rectified output. The 230 VAC torac module output is a ½ wave rectified 100 VDC .
6. The 115 VAC torac module has yellow leadwires. The 230 VAC torac has blue leadwires.

Torac™ Connection with SM-brake or clutch

Torac fusing: 1 ampere, fast acting

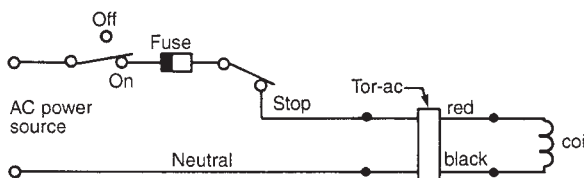

Torac™ Connection with SM clutch-brake

(use two torac: one for each coil.)

Torac fusing: 1 ampere, fast acting

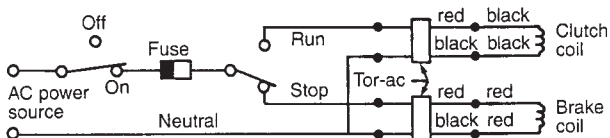

Coil Resistance:

	24-28 VDC		90-100 VDC & 115/230 VAC through Torac™ module rectifier	
	Clutch	Brake	Clutch	Brake
SM 50	78	43	760	670
SM 100 & 180	31	27	440	425

Torac™ Troubleshooting:

1. Torac modules are used with 90 VDC coils.
2. Check the torac module by removing all loads, disconnecting from the coil and insulate the output leads. Replace the fuse. If the fuse blows with AC application, the Torac module should be replaced.
3. Do not use a slow blow or time delay fuse.
4. Compare AC voltage at torac module to AC rating & leadwire color (see torac module section).
5. Check DC voltage with power across the SM unit coil. If the coil is not connected to power, reading will be high and inaccurate.
6. The coil is checked on the DC side.

Troubleshooting SM Engagement:

Review the full installation sheet.

1. Compare nameplate voltage to the voltage measured at each SM coil.
2. Compare coil to the resistance chart.
3. Check for damaged and grounded leadwires.

Troubleshooting New installations:

Check above sections.

1. Confirm pressed in key is in place with both setscrews fit into the shaft and key. If the shaft to hub fit is forced at installation, the pressed in key may move forward causing internal binding.
2. Start & stop times generally are one second or less. Sizing charts with sizing factors are in the catalog which is available at www.rexnord.com/stearns.
3. Eccentric rotation at the output shaft: Check the mount surface as burrs and knicks will prevent accurate C-face registration.
4. Confirm the control circuit powers clutch and brake separately.
5. Do not use a slow blow or time delay fuse.

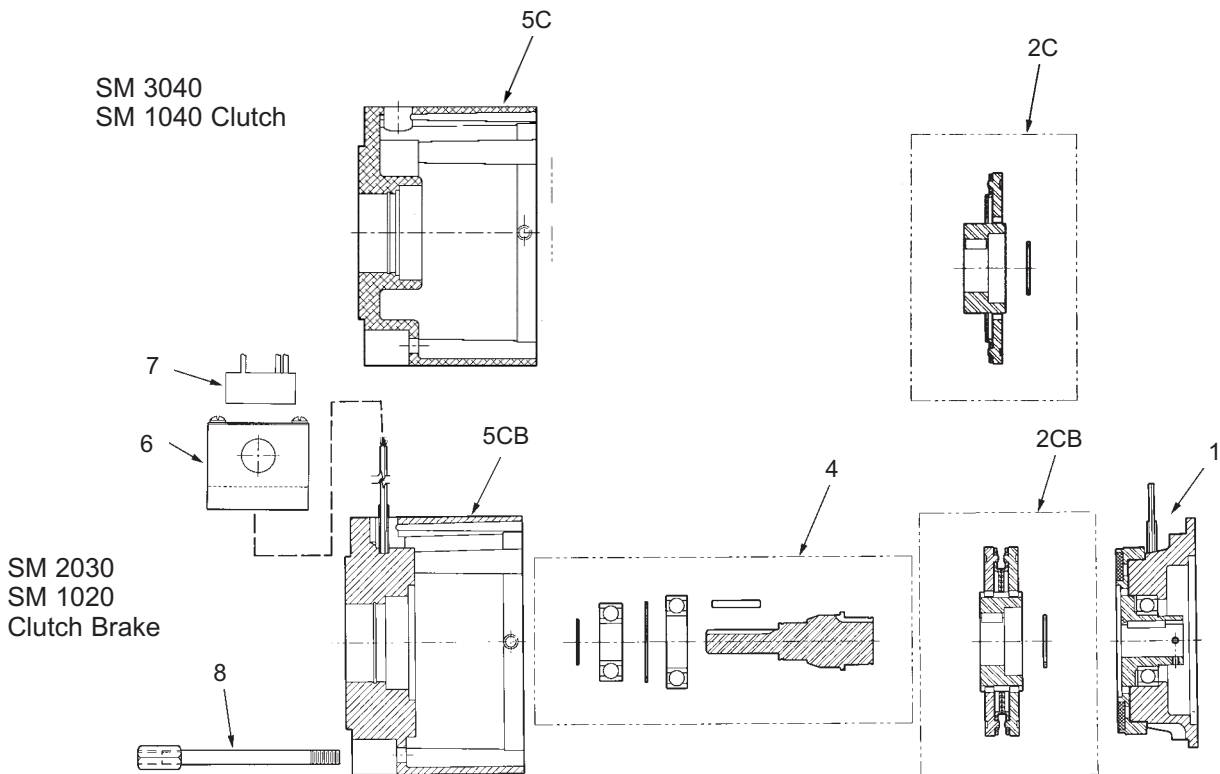

Item	Description	Part Number
1	Clutch side magnet body with coil & bearing	Replace SM
2C (Clutch) 2CB (Clutch brake)	Armature with drive hub, self adjust & grip ring	Replace SM
4	Output shaft and bearings	Replace SM
5C (Clutch) 5CB (Clutch Brake)	Housing Housing with brake side magnet body & coil	Replace SM
6	Conduit box with gasket & cover	5-77-1016-00
7	Torac (use with 90 VDC coils) Clutch use quantity 1 Clutch brake use quantity 2	Rectifier: 230 VAC, 50/60 Hz 4-1-20290-00K 115 VAC, 50/60 Hz 4-1-20194-00K
8	Nut and stud assembly; quantity 4	9-09-0008-00
<i>Optional Kits:</i> Size 50 & 100 Size 180	Base kit for use with clutch or clutch brake 5-78-1101-01 5-78-1101-02	Input Adapter Kit 5-78-6100-31 5-78-6100-32

6. External rectifier check: Check bridge by removing all loads and replacing the fuse. If the fuse blows when AC is applied to the rectifier, the bridge is shorted and should be replaced

General Loss of Torque:

Read through instructions & troubleshooting sections.

- Air gap is factory set and auto-adjusted. Gap is not field modified.
- Internal engagement is metal to metal: armature to pole face. Do not machine internal surfaces to extend product life. Replace the SM assembly when worn.
- The friction surface is not replaceable and is used to isolate the pole faces. Pole faces are slightly above the friction surface in a new SM unit.
- Do not lubricate internal parts. Do not use anti-seize internally.

Kits:

The basic SM1020 clutch brake or SM 1040 can be modified for mechanical coupling or parallel shaft use by adding the base kit and input adapter kit. The input adapter kit fits to the SM assembly C-face. The input adapter kit does not have an output C-face.

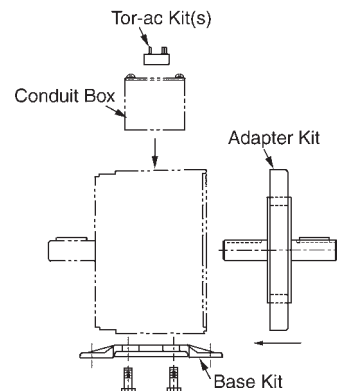

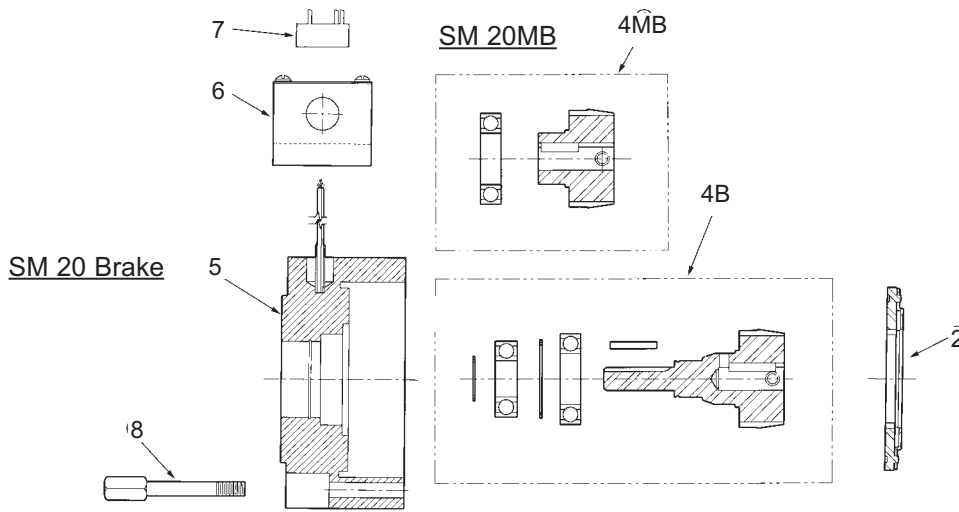

Item	Description	Part Number
2	Armature, self adjust & grip ring	Replace SM
4MB (brake) 4B (brake with shaft)	Hub & bearing kit	Replace SM
5	Housing	Replace SM
6	Conduit box with gasket & cover	5-77-1016-00
7	Torac (use with 90 VDC coils) Use one	115 VAC, 50/60 Hz 4-1-20194-00K 230 VAC, 50/60 Hz 4-1-20290-00K
8 MB	Bolts, quantity 4	9-16-3240-00
8	Nut & stud assembly, quantity 4	9-09-0008-01

Input Adapter Kit

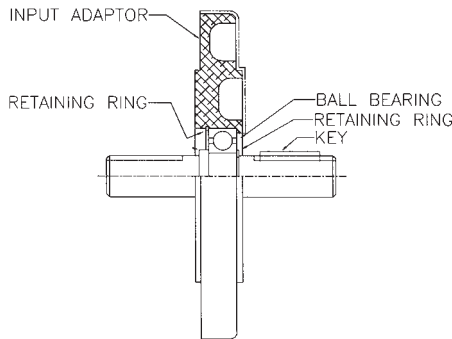

- Make sure drive hub set screws are backed out sufficiently to allow shaft clearance.
 - The drive hub set screws are accessible through access hole on side of SM unit. Replace the plug after tightening the set screws.
- Position and align the adapter plate to allow it to freely slide into the drive hub (machined surface toward Super-Mod unit). Slide the adapter plate shaft into the drive hub until the C-face flanges meet.
 - If adapter plate shaft does not slide freely into the drive hub, polish the shaft and/or keyway until smooth slip fit is achieved.
- After mating the C-face flanges, insert the four tie bolts (supplied with SM unit) and alternately finger tighten, then torque to 38 lb. ft.
 - Tighten the drive hub set screws, using the proper size hex wrench (wrench provided with SM unit) to 150 lb. in.
- Set screw alignment can be accomplished by rotating the keyed adapter shaft and drive hub. A flashlight will help in finding the two set screws as the input shaft is rotated. Be sure the hex wrench (allen key) is fully inserted into the set screws during tightening.
 - Reinstall set screw access plug.
- The two shaft extensions provide the means of connecting the unit to the drive and driven elements in the system by means of direct coupling, sheaves, sprockets, or other pulley and belt combinations. When using a coupling, follow manufacturer's alignment procedures.

Base Kit

- Remove four plug (allen) screws from the bottom of the Super-Mod unit (side opposite the conduit box).
- Position base plate against flat surface of Super-Mod housing with the notched side toward the output shaft as shown in Figure 2.
- Secure the base plate to the Super-Mod housing using the 4 mounting bolts included with the kit. Tighten to 20-27 lb. ft.

Description of Parts Included in Kit	Quantity Per Kit
Base plate	1
Mounting bolts	4

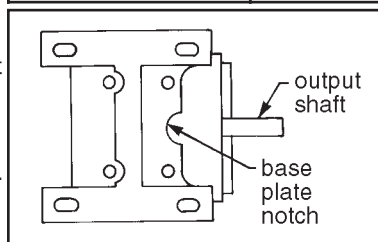

Figure 2



Rexnord Industries, LLC.
 Stearns Division
 5150 S. International Dr.
 Cudahy, Wisconsin 53110
 (414) 272-1100 Fax: (414) 277-4364 www.rexnord.com