

1-081-000 & 1-082-000 series spring-set brakes

Direct Mount to Nema 324 – 405 TC NEMA C-face registers



- 125 - 440 lb-ft
- Spring set, electrically released
- Enclosure ratings: IP 23, 54, 56
- Adaptable to other mount register
- Broad range of material and construction options

Construction:

The 1-081-000 and 1-082-000 series have the same support plate assembly including springs and coils. Both series have the same Nema C-face mounting register dimensions. The brakes differ in the disc pack construction. The 1-081-000 series has a (3) tab disc pack design suitable for lighter dynamic applications. The 1-082-000 series disc pack has a full gear cut construction (above picture) which results in greater mass and contact area resulting in higher thermal capacity making it more suitable in dynamic stopping and high torque applications.

Shown: pressure plate, friction disc, stationary ring and hub

Top: 1-082-000 gear cut disc pack

Lower: 1-081-000 tab construction disc pack

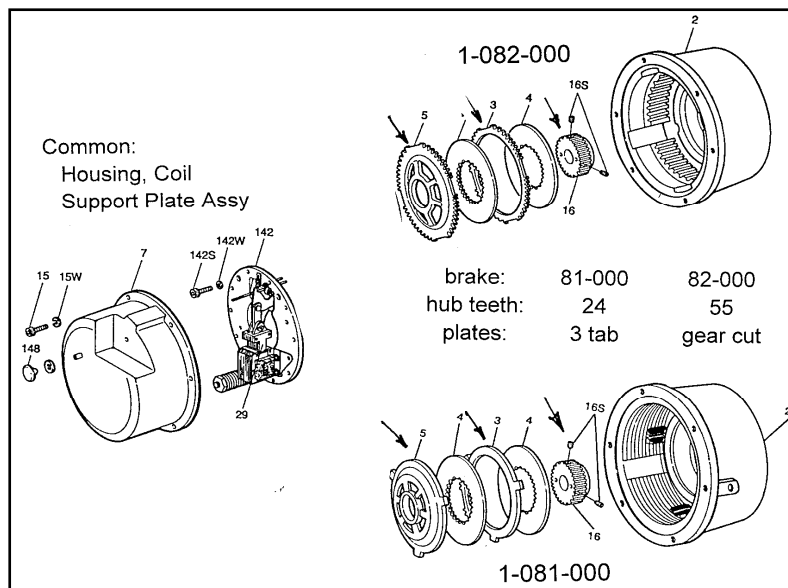

Catalog:

Brake torque is the result of spring force on the disc pack which is located about the shaft mounted gear cut hub. Torque increments occur by adding to the disc pack count as well as increasing the spring & coil force. Disc pack strength and thermal capacity are considered separately from stopping or holding torque.

1-081-000	X	X	X		
1-082-000	X	X	X	X	X
LB-Ft	125 ▲	175	230	330	440
number of discs	2	2	3	3	4
coil size	9	9	9	K9	K9
spring color code	Green	Yellow	Yellow	Red	Red

Thermal capacity is a measure of how much frictional heat resulting from dynamic use can routinely be absorbed & dissipated. The 1-081-000 series is rated at 30 hp-sec/minute while the 1-082-000 is rated at 50 hp-sec/minute.

▲ the 1-087-100 series (284TC frame) is available at a rated 125 lb-ft; thermal capacity is 20 hp-sec/minute.

The 1-081-000 & 1-082-000 are identical in the support plate assembly including the torque spring and coil. The spring is force matched to the coil. The brakes are spring set with electrical release.

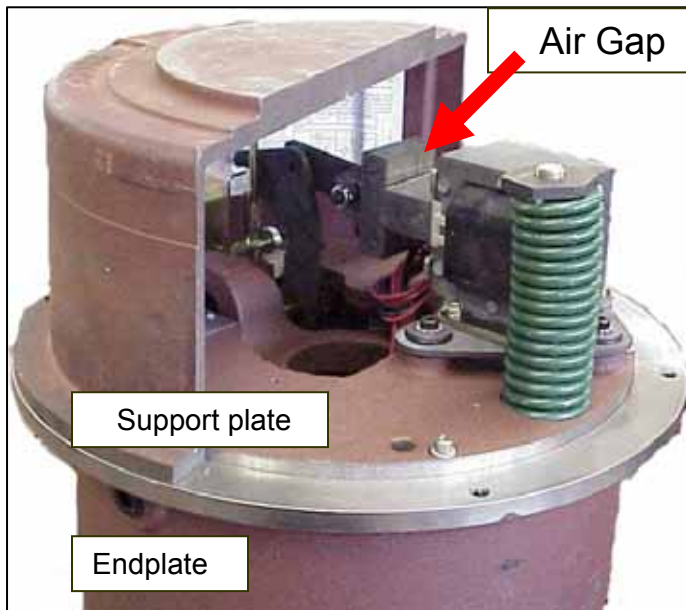

Shown: Support Plate Assembly mounted to the endplate. The disc pack and gear shape hub are located within the endplate.

The common brake construction and material options are listed in the print or on-line catalog found at: www.stearns.rexnord.com. Other options may be recommended when additional application information and specifications are provided.

Basic maintenance Check List:

- Review the service & installation sheet before mounting the brake to a motor C-face register. Brakes are repairable; mark the 12 digit model number and serial number on the support plate for future use. The information is printed on the brake nameplate.
- The brake is electrically released & spring set. The plunger moves in and out of the coil within milli-seconds.
- Fully seat and then bind the plunger into the coil before removing the support plate from the endplate.
- The plunger should fit smoothly into the solenoid.
- Factory air gap: 1 3/8"
- Routine maintenance includes inspection of the disc pack for wear or glazing and a visual check of the linkage points for excess wear.
- Check for corrosion, fretting, oil, grit, or wear and mechanical binding.
- Keep lead-wires out of moving parts & pinch-points.

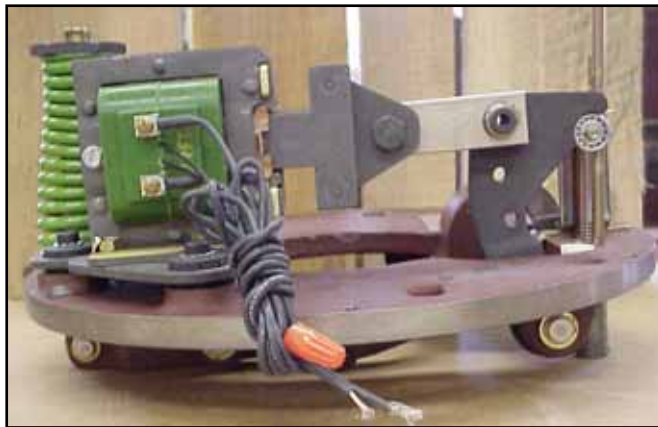

Shown top: Check for binding or wear at linkage points, including the self adjust rack & pinion on the underside of the support plate.

Shown below: Replace severely glazed (middle) or charred (right) friction discs. Replace friction discs when the discs are worn to 1/3 to 1/2 of the individual disc thickness, or when 1/2 the total disc pack, including plates, is worn. Check for notching in the gear or tab track sections.

Stearns[®]: Reliable brakes through design, manufacture and support.

Prior e-letter tech sheets are posted on the Stearns web site: www.stearns.rexnord.com

Stearns[®] E-Letter April 2010