

Super-Mod® Clutch Only Modules: SM-1040, SM-1040WD (Washdown) and SM-3040B

DIMENSIONS

[BACK TO TABLE OF CONTENTS](#)

[BACK TO SM PRODUCT OVERVIEW](#)

[INSTALLATION & PARTS LIST BY SIZE: 50/100/180
210/250](#)

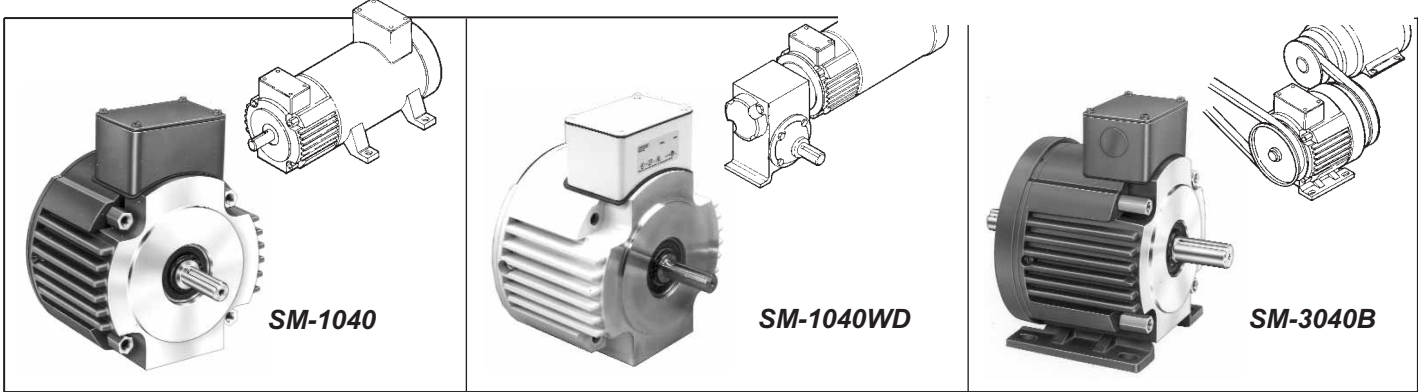

- 48Y (56C) through 215TC (256C) NEMA Frame Sizes
- 16 through 145 lb-ft Static Torque; 2400 Maximum RPM
- TENV – Totally Enclosed (Non-Ventilated) IP-54 Enclosure Protection, (IP-55 for Washdown Units)
- Listed by Underwriters Laboratories, Inc., File E-71115 and CSA Certified, File LR-6254
- Maximum overhung load capacity is 85 lbs

Performance Data, Ordering Information and List Prices

Static Torque lb-ft	Dynamic Torque lb-ft	NEMA Frame	Model	Part Number ^①	Thermal Capacity (ft-lb/min) ^②	Wt. (lbs)	Maximum Electrical Power (watts)	Dimension Page	Competitive Interchange Page	List Price ^③	Discount Symbol
16	10	56C/48Y	SM-50-1040	2-36-0561-01-A*L	5000	20	19	17	19	\$1046.00	X-8
16	10	56C/48Y	SM-50-1040B	2-36-0561-01-B*L	5000	22	19	17	19	1102.00	X-8
16	10	56C/48Y	SM-50-1040WD	2-36-0562-01-A*L	5000	20	19	17	19	1276.00	X-8
16	10	56C/48Y	SM-50-3040	2-36-0561-01-C*L	5000	20	19	18	20	1222.00	X-8
16	10	56C/48Y	SM-50-3040B	2-36-0561-01-D*L	5000	24	19	18	20	1278.00	X-8
35	20	56C/48Y	SM-100-1040	2-36-0561-02-A*L	5000	20	29	17	19	1338.00	X-8
35	20	56C/48Y	SM-100-1040B	2-36-0561-02-B*L	5000	22	29	17	19	1394.00	X-8
35	20	56C/48Y	SM-100-1040WD	2-36-0562-02-A*L	5000	22	29	17	19	1632.00	X-8
35	20	56C/48Y	SM-100-3040	2-36-0561-02-C*L	5000	22	29	18	20	1626.00	X-8
35	20	56C/48Y	SM-100-3040B	2-36-0561-02-D*L	5000	24	29	18	20	1684.00	X-8
35	20	180C/140TC	SM-180-1040	2-36-1401-02-A*O	5000	20	29	17	19	1338.00	X-8
35	20	180C/140TC	SM-180-1040B	2-36-1401-02-B*O	5000	22	29	17	19	1418.00	X-8
35	20	180C/140TC	SM-180-1040WD	2-36-1402-02-A*O	5000	20	29	17	19	1632.00	X-8
35	20	180C/140TC	SM-180-3040	2-36-1401-02-C*O	5000	22	29	18	20	1626.00	X-8
35	20	180C/140TC	SM-180-3040B	2-36-1401-02-D*O	5000	24	29	18	20	1706.00	X-8
75	44	210C/180TC	SM-210-1040	2-36-1801-03-A*R	7000	31	16	17	19	2374.00	X-8
75	44	210C/180TC	SM-210-1040B	2-36-1801-03-B*R	7000	31	16	17	19	2496.00	X-8
75	44	210C/180TC	SM-210-3040	2-36-1801-03-C*R	7000	31	16	18	20	2916.00	X-8
75	44	210C/180TC	SM-210-3040B	2-36-1801-03-D*R	7000	31	16	18	20	3036.00	X-8
145	86	250C/210TC	SM-250-1040	2-36-2101-04-A*U	5600	31	38	17	19	2600.00	X-8
145	86	250C/210TC	SM-250-1040B	2-36-2101-04-B*U	5600	31	38	17	19	2720.00	X-8
145	86	250C/210TC	SM-250-3040	2-36-2101-04-C*U	5600	31	38	18	20	3228.00	X-8
145	86	250C/210TC	SM-250-3040B	2-36-2101-04-D*U	5600	31	38	18	20	3348.00	X-8

② Thermal capacity rating is based on ambient temperature of 70°F at 1750 RPM.

③ List prices subject to change without notice.

SM Clutch Module Guide:

SM-1040 – Standard (direct-coupled)

SM-1040B – Standard with Base

SM-1040WD – IP-55 Washdown (available in NEMA frame sizes 56C-145TC)

SM-3040 – Standard with Clutch Input Adapter

SM-3040B – Clutch Input Adapter Plus Base

① Example of a complete part number:

2-36-0561-01-AJL — 5/8 hub

└── 90-100 Vdc

└── Basic unit

└── 0=Standard Unit

└── 2= Without Gap Adjust

Options - Features Table

Series	Character	Description
SM-1040	A	Basic unit
SM-1040B	B	Basic unit plus base
SM-3040	C	Basic unit plus clutch input adapter
SM-3040B	D	Basic unit plus base & clutch input adapter

Specials available upon request.
Consult factory for list price adder.

Voltage Table

Character	Voltage	List Adder
C	12 Vdc	
E	24-28 Vdc	none
J	90-100 Vdc	
N	115 Vac	\$92.00
P	230 Vac	110.00

Hub Size Table for SM-1040's

Character	Bore	Keyway
L	5/8	3/16 x 3/32
O	7/8	3/16 x 3/32
R	1 1/8	1/4 x 1/8
U	1 3/8	5/16 x 5/32

Super-Mod® Dimensional Data

[BACK TO SM PRODUCT OVERVIEW](#)

SM-1020, SM-1040, SM-20 and SM-20MB

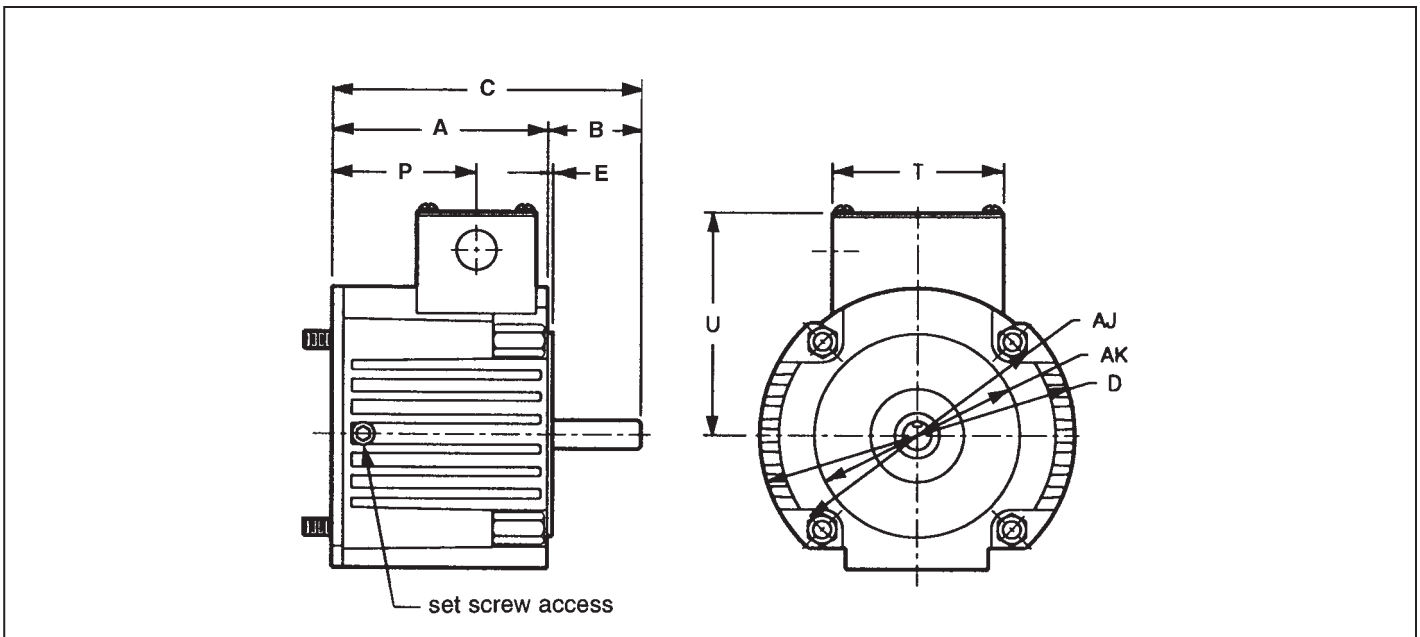

NEMA C-Face Frame Size	Configuration	Basic Module Style	Basic Model Number	AJ	AK	Hub bore and shaft ø	Keyway	A	B	C	D	E	P	T	U
SM-50 SM-100 48Y/56C 5/8 hub bore 5/8 shaft	C-face Clutch/Brake	1020	2-35-056X-0X-A*L	5.875	4.5	5/8	3/16 x 3/32	4.71	2.06	6.77	6.9	.16	3.15	2.8	4.9
	C-Face Clutch Only	1040	2-36-056X-0X-A*L					3.14		5.2			2.92		
	C-Face Brake Only	20	2-37-056X-0X-A*L					-	-	-					
	C-Face Brake Only without Shaft	20MB	2-37-056X-0X-X*L					-	-	-					
SM-180 182C/145TC 184C/145TC 7/8 hub bore 7/8 shaft	C-face Clutch/Brake	1020	2-35-140X-02-A*O	5.875	4.5	7/8	3/16 x 3/32	4.71	2.12	6.83	6.9	.16	3.15	3.8	4.9
	C-Face Clutch Only	1040	2-36-140X-02-A*O					3.14		5.25			1.58		
	C-Face Brake Only	20	2-37-140X-02-A*O					-	-	-					
	C-Face Brake Only without Shaft	20MB	2-37-140X-02-X*O					-	-	-					
SM-210 213C/182TC 215C/184TC 1-1/8 hub bore 1-1/8 shaft	C-face Clutch/Brake	1020	2-35-1801-03-A*R	7.25	8.5	1-1/8	1/4 x 1/8	6.11	2.59	8.7	9	.25	2.83	4	7.4
	C-Face Clutch Only	1040	2-36-1801-03-A*R					4.61		7.2			2.17		
	C-Face Brake Only	20	2-37-1801-03-A*R					-	-	-					
	C-Face Brake Only without Shaft	20MB	2-37-1801-03-X*R					-	-	-					
SM-250 254C/213TC 256C/215TC 1-3/8 hub bore 1-3/8 shaft	C-face Clutch/Brake	1020	2-35-2101-04-A*U	7.25	8.5	1-3/8	5/16 x 5/32	6.11	3.03	9.14	9	.25	2.83	4	7.4
	C-Face Clutch Only	1040	2-36-2101-04-A*U					4.61		7.64			2.17		
	C-Face Brake Only	20	2-37-2101-04-A*U					-	-	-					
	C-Face Brake Only without Shaft	20MB	2-37-2101-04-X*U					-	-	-					

Super-Mod® Dimensional Data

BACK TO SM PRODUCT OVERVIEW

SM-2030B and SM-3040B

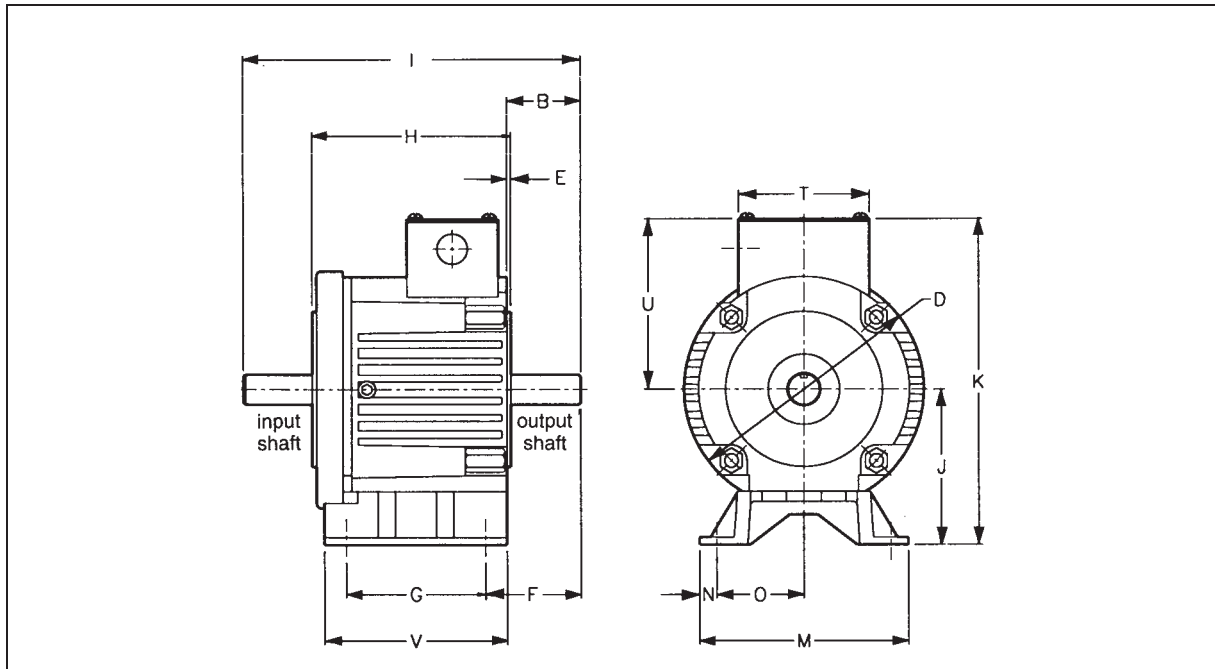

NEMA C-Face Frame Size	Configuration	Basic Module Style	Basic Model Number	Shaft ø	Keyway	B	D	E	F	G	H	I	J	K	M	N	O	T	U	V
SM50 SM100 48Y/56C 5/8 shaft	Base Mount Clutch/Brake- Double Shaft	2030B	2-35-056X-0X-D*L	5/8	3/16 x 3/32	2.06	6.9	.16	2.76	4	5.9	9.55	3.5	8.4	6	0.5	2.5	3.8	4.9	5.25
	Base Mount Clutch Only- Double Shaft	3040B	2-36-056X-0X-D*L	5/8	3/16 x 3/32															
SM-180 182C/145TC 184C/145TC 7/8 shaft	Base Mount Clutch/Brake- Double Shaft	2030B	2-35-140X-0X-D*O	7/8	3/16 x 3/32	2.12	6.9	.16	2.82	4	5.9	9.61	4.5	9.4	6	0.5	2.5	3.8	4.9	5.25
	Base Mount Clutch Only- Double Shaft	3040B	2-36-140X-0X-D*O	7/8	3/16 x 3/32															
SM-210 213C/182TC 215C/184TC 1-1/8 shaft	Base Mount Clutch/Brake- Double Shaft	2030B	2-35-1801-03-D*R	1-1/8	1/4 x 1/8	2.59	9	.25	3.41	6	6.91	12.09	5.25	12.65	9	0.63	3.87	4	7.4	8
	Base Mount Clutch Only- Double Shaft	3040B	2-36-1801-03-D*R	1-1/8	1/4 x 1/8															
SM-250 254C/213TC 256C/215TC 1-3/8 shaft	Base Mount Clutch/Brake- Double Shaft	2030B	2-35-2101-04-D*U	1-3/8	5/16 x 5/32	3.03	9	.25	3.88	6	6.91	12.97	5.25	12.65	9	0.63	3.87	4	7.4	8
	Base Mount Clutch Only- Double Shaft	3040B	2-36-2101-04-D*U	1-3/8	5/16 x 5/32															